

PERMIT APPLICATION

Thomas Malavasi, PE, PP, CME, CPWM
County Engineer

HUDSON COUNTY
OFFICE OF THE COUNTY ENGINEER
830 BERGEN AVENUE, FLOOR 6-B
JERSEY CITY, NEW JERSEY 07306-4507
TEL: 201-369-4340/FAX: 201-369-4346

Call Before You Dig
1-800-272-1000
OR 811

INFRARED
REQUIRED

Permit for: ( ) Road Opening ( ) Curb( ) Sidewalk ( ) Bridge ( ) Traffic Plan ( ) Dumpster
( ) Other:

(PRINT & SIGN)

Name of Municipality: Date:
Location of Work:
Property Owner: Phone number:
Address: Cross Street:
Contractor: Phone number:
Address:
Type of work:
Will a crane be used?

Total Area of Road Opening: SF Width: FT Length: FT Depth: FT
Total Linear FT. of Std. Curb: Depressed Curb: FT Total Number of Openings:
Class of Pavement - Concrete Bituminous Concrete: Other
Remarks:

Hudson County roadway lane closure hours are from 9:00 a.m. to 5:00 p.m. Monday through Friday, excluding
Holidays (including Election Day), unless approved by the County Engineer.

Date work will be started on: Finished by:
Call 1-800-272-1000 72 hours before any excavation for utility mark outs.

Attach 3 copies of a sketch or plans showing location and dimensions of proposed work. Traffic Control Plan, Insurance Certificate, Check/Money Order,
Bond, Municipal permits, and/or Planning Board Approval. Copies of all local building or any other applicable permits must be attached. Lane closures
will require a traffic control plan. All permits will require approval pursuant to Executive Order TAD-67.

All work must conform to construction standards of jurisdiction and the requirements of attached conditions and Hudson County Ordinance # 116-2-1999
as amended. The Permittee agrees to comply with the current laws of the Federal Government and the State of New Jersey. The acceptance of this permit
shall be deemed an agreement to abide by all terms conditions and requirements as set forth by the County of Hudson. Notice must be given 24 hours
before work starts to the County Engineer for inspections.

This application must be made and approved before any work is started, except in cases of emergency. Telephone notice of an emergency must be
made immediately and followed by a written permit within 24 hours of notice and/or the next business day. Failure to comply with the emergency
procedures may be subject to fines in accordance with Ordinance 405-6-2017. The original permit must be available at the site at all times when work
is in progress.

Applicant Signature: Fax Number:

"I hereby certify that I have received and read a copy of Ordinance #116-2-1999 and the amendment and agree to the terms and
conditions of the ordinance and as indicated in this application."

Print Name: Cell-phone Number:
E-Mail:

DO NOT WRITE BELOW THIS LINE

App Fee \$50.00 Permit fee \$ Guarantee Bond ( ) Insurance Y ( ) N ( )

Application Approved By: Title : Date:

Conditional Requirements: All work as per OSHA-NJDOT-MUTCD-NJDEP
Infrared repave to all road openings. Full slab restoration to all sidewalk openings. All curbing, drop curbing and sidewalk
restoration as per County & NJDOT specs

Permit Expiration Date: Permit Number:
Extended to Date Initials

County of Hudson  
Department of Roads & Public Property  
Office of the County Engineer  
830 Bergen Avenue, Floor 6B  
Jersey City, New Jersey 07306-4507  
T-201-369-4340/F-201-369-4346

Thomas DeGise  
County Executive

Thomas Malavasi, PE, PP, CME, CPWM  
County Engineer

Denise D'Alessandro  
Director, Roads & Public Property

RE: Additional Conditions for Road Opening Permits

**Any applicant applying for a Road Opening Permit shall comply with the following additional conditions which are made a part of this permit.**

- 1. Any use of County roads, structures or facilities which impede vehicular and/or pedestrian traffic shall necessitate the employment of a Police Traffic Director for directing and management of traffic. Please contact the appropriate municipal police.**
2. The applicant is required to notify the County Engineer's Office at least 48 hours prior to the starting of work at 201-369-4340.
3. The Road Opening Permit shall not be effective until applicant provides proof to the County that "One Call" Damage Prevention System 1-800-272-1000 has been notified.
4. Emergency Contact Person with (24 hour) telephone numbers must be provided.
- 5. All construction shall be in accordance with "NJDOT Standard Specifications for Road & Bridge Construction" 2019 amended.**
6. Provide necessary lights, barricades, plates and a clear walkway at all times during the course of work to protect the traveling public. All work area signs and barricades shall be as per MUTCD requirements.
7. All backfill is to be done with quarry process stone Type 1-5 or DGA for the full depth of the trench.
8. The pavement is to be restored with ten inches (10") of HMA 25M64 and two inches (2") of 12.5M64 properly compacted. Final restoration must be completed within thirty (30) days of the opening. (Seasons permitting) infrared repave shall be required to all road openings, regardless to age and/or condition to the existing roadway.
9. Any opening of ten feet (10') or longer shall be milled to a depth of two inch (2") overlapping edges of the opening by twelve inches (12")
10. Edges of the trench shall be cut in a straight line with a saw. The base is to be squared and cut on a vertical plane to a width and length of not less than twelve inches (12") greater than the original cut. The surface restoration shall extend twelve inches (12") wider and longer than the area of the base.
11. Any disturbed pavement markings must be restored immediately. Pavement markings must be restored to original or better condition. The restoration to construction must use the same or equivalent materials (3M-WR Thermoplastic Intermix) as originally installed. The restoration may be temporary (using paint) until the permanent markings are applied within thirty (30) days. Hudson County shall be held harmless in any and all accidents arising out of this work.
12. Excavation of Belgium blocks (Cobble Stones) or any other salvageable material from County Streets/Roads (with exception to historical roads) must be stock piled and later brought by the contractor or his designee to a designated site under the direction of the County Engineer.
13. For roads paved within the last five years, enhanced restoration methods will be utilized in accordance with Ordinance 529-9-2016. In Union City, their requirements for roads paved within the last 10 years shall be met.
14. If underground utility lines are to be decommissioned, the County will not take ownership of the abandoned lines. For pipelines, they shall either be removed or filled with inert, compacted material and sealed at both ends. If utility lines are to be left in place they shall continue to be marked out as part of the One Call System.
15. If overhead utility lines are to be decommissioned, the County will not take ownership of the abandoned lines. Decommissioned overhead wiring shall be removed and left in a neat, safe condition.

Thomas Malavasi, PE, PP, CME, CPWM  
County Engineer  
Revised: February 2020

## FEE SCHEDULE

### Road Opening Permits:

Application Fee	
Normal	\$50.00
Non Reported Opening	\$200.00
Permit Fee (Opening Size)	
Up to 20 S.F.	\$100.00 (Min)
Between 20 and 80 S.F. Additional	\$250.00
over 80 S.F.	\$1.00/S.F.
<b>Multiple Openings (Min)</b>	\$100.00 Each

### Road Opening Bond

Up to 20 S.F.	\$5000.00 (Min)
Over 20 S.F.	\$5000.00 plus \$20.00 per S.F. over 20 S.F.
Multiple Openings (Min)	\$5000.00 Each
Newly Paved Roads (5 years or less)	\$50,000.00 or as determined by the County Engineer

### Curb & Driveway Permits

Application Fee	\$50.00
Permit Fee For	\$100.00 (Min)
Depressed Curb (Driveway Opening) or	\$1.00/L.F. (\$100.00 Min)
Full Height Curb	
Guarantee Bond	\$5000.00 (min)
Single Driveway	
	\$10,000.00 (min)
All Others	

### Bridge Permits

Application Fee	\$100.00
Permit Fee	\$500.00
All work within 10' of Bridge	Same as Road Opening Fee
Outside of these limits	above

### Guarantee Bond

All work within 10' of Bridge	\$25,000.00 (min) or as
Outside of these limits	determined by the County Engineer

### Dumpster Permits

Permit Fee	\$25.00 per month
------------	-------------------

**Revised June 2019**

**ACORD™ CERTIFICATE OF LIABILITY INSURANCE**

DATE (MM/DD/YYYY)

PRODUCER

THIS CERTIFICATE IS ISSUED AS A MATTER OF INFORMATION ONLY AND CONFERS NO RIGHTS UPON THE CERTIFICATE HOLDER. THIS CERTIFICATE DOES NOT AMEND, EXTEND OR ALTER THE COVERAGE AFFORDED BY THE POLICIES BELOW.

INSURED

**YOUR COMPANY NAME**

INSURERS AFFORDING COVERAGE

NAIC #

INSURER A

INSURER B

INSURER C

INSURER D

INSURER E

**COVERAGES**

THE POLICIES OF INSURANCE LISTED BELOW HAVE BEEN ISSUED TO THE INSURED NAMED ABOVE FOR THE POLICY PERIOD INDICATED NOTWITHSTANDING ANY REQUIREMENT, TERM OR CONDITION OF ANY CONTRACT OR OTHER DOCUMENT WITH RESPECT TO WHICH THIS CERTIFICATE MAY BE ISSUED OR MAY PERTAIN. THE INSURANCE AFFORDED BY THE POLICIES DESCRIBED HEREIN IS SUBJECT TO ALL THE TERMS, EXCLUSIONS AND CONDITIONS OF SUCH POLICIES. AGGREGATE LIMITS SHOWN MAY HAVE BEEN REDUCED BY PAID CLAIMS.

INSURANCE TYPE	TYPE OF INSURANCE	POLICY NUMBER	POLICY EFFECTIVE DATE (MM/DD/YYYY)	POLICY EXPIRATION DATE (MM/DD/YYYY)	LIMITS
GENERAL LIABILITY	COMMERCIAL GENERAL LIABILITY	Sample			EACH OCCURRENCE \$
	CLAIMS MADE <input type="checkbox"/> OCCUR <input type="checkbox"/>				DAMAGE TO RENTED PREMISES (EA OCCUR) \$
	GEN'L AGGREGATE LIMIT APPLIES PER:				MED EXP (Any one person) \$
	POLICY <input type="checkbox"/> PRO <input type="checkbox"/> JEG <input type="checkbox"/> LOC <input type="checkbox"/>				PERSONAL & ADV INJURY \$
AUTOMOBILE LIABILITY	ANY AUTO				GENERAL AGGREGATE \$
	ALL OWNED AUTOS				PRODUCTS COMP/OP AGG \$
	SCHEDULED AUTOS				
	HIRER AUTOS				
	NON OWNED AUTOS				
GARAGE LIABILITY	ANY AUTO				COMBINED SINGLE LIMIT (EA accident) \$
					BODILY INJURY (Per person) \$
					BODILY INJURY (Per accident) \$
					PROPERTY DAMAGE (Per accident) \$
EXCESS/UMBRELLA LIABILITY	OCCUR <input type="checkbox"/> CLAIMS MADE <input type="checkbox"/>				AUTO ONLY - EA ACCIDENT \$
	DEDUCTIBLE				OTHER THAN EA ACC \$
	RETENTION \$				AUTO ONLY: AGG \$
WORKERS COMPENSATION AND EMPLOYERS' LIABILITY	ANY PROPRIETOR/PARTNER/EXECUTIVE OFFICER/MEMBER EXCLUDED? <input type="checkbox"/>				EACH OCCURRENCE \$
	If yes, describe under SPECIAL PROVISIONS below				AGGREGATE \$
	OTHER				WORKERS COMPENSATION LIMIT \$
					OTH EDL \$
					E L EACH ACCIDENT \$
					E L DISEASE EA EMPLOYEE \$
					DISEASE - POLICY LIMIT \$

DESCRIPTION OF OPERATIONS / LOCATIONS / VEHICLES / EXCLUSIONS ADDED BY ENDORSEMENT / SPECIAL PROVISIONS

ADDRESS OF WORK LOCATION & TYPE OF WORK BEING PERFORMED.  
 "COUNTY OF HUDSON" MUST BE NAMED AS ADDITIONAL INSURED.

**CERTIFICATE HOLDER**

COUNTY OF HUDSON  
 830 BERGEN AVE., 6-B  
 JERSEY CITY, NEW JERSEY 07306-4507

**CANCELLATION**

SHOULD ANY OF THE ABOVE DESCRIBED POLICIES BE CANCELLED BEFORE THE EXPIRATION DATE THEREOF, THE ISSUING INSURER WILL ENDEAVOR TO MAIL \_\_\_\_\_ DAYS WRITTEN NOTICE TO THE CERTIFICATE HOLDER NAMED TO THE LEFT, BUT FAILURE TO DO SO SHALL IMPOSE NO OBLIGATION OR LIABILITY OF ANY KIND UPON THE INSURER, ITS AGENTS OR REPRESENTATIVES.

AUTHORIZED REPRESENTATIVE

BOARD OF CHOSEN FREEHOLDERS  
COUNTY OF HUDSON  
**ORDINANCE**

No. 166-4-1999

On Motion of Freeholder Cifelli

Seconded by Freeholder Carroll

AN ORDINANCE REPLACING ORDINANCE NO. 166-4-1984  
REGARDING THE RULES AND REGULATIONS  
GOVERNING ROAD OPENING PERMITS

WHEREAS, pursuant to the provisions of N.J.S.A. 40:41A-38, 40:41A-101 and 27:16-31, the County of Hudson established rules and regulations governing road opening permits which were adopted by the Board of Chosen Freeholders by Ordinance No. 166-4-1998; and

WHEREAS, the Hudson County Engineer has prepared and recommended to this Board an Ordinance replacing Ordinance 166-4-1984.

NOW, THEREFORE, BE IT ORDAINED, by the Board of Chosen Freeholders, that:

1. The following are the Rules and Regulations, including fees which shall govern road opening permits within the County of Hudson:

**I. GENERAL REQUIREMENTS & RESPONSIBILITIES**

No person, firm, corporation, public utility, authority or municipality shall hereinafter tear up, open, remove, construct, reconstruct or excavate any portion of any road, curb, sidewalk or bridge or any utility, facility or any portion thereof, in the County of Hudson, owned, maintained or controlled by the County of Hudson as part of the County road system, for any purpose whatsoever without first making application for and receiving a permit thereof, signed in the name of the County of Hudson by the County Engineer or one of his authorized agents.

**II. ROAD OPENING PERMITS**

The written application shall state the name and address of the applicant, the name and address of the contractor performing the work, emergency phone numbers, name of the County road to be opened, the nature, location and purpose of the work, anticipated time of completion, a statement that the permittee will comply with the ordinances & regulations and laws related to the proposed work and any other data as may be reasonably required by the County Engineer. The application shall be accompanied by a reasonably accurate sketch plan in triplicate, showing the location and dimensions of the proposed work. A separate permit shall be required for each and every opening unless otherwise agreed upon. The applicant shall sign the permit application and shall be bound for all obligations of the permit and shall be referred to hereafter as permittees. A permit shall not be transferred except upon prior written consent of the County Engineer.

The County will charge the permittee according to the Fee Schedule as attached. The permittee, to whom a permit has been issued, shall not disturb or remove pavement or perform any work other than that for which this permit provides for.

**III. GENERAL FINANCIAL OBLIGATIONS**

All permittees including Public Utilities, Municipalities, their contractors or contractors of State or Federal agencies, shall deposit a guarantee with the Treasurer of the County of Hudson in the form of a Bond, Certified Check or Bank Draft acceptable to the County. The deposits required herein shall be held in a separate account by the County and will carry no interest to the permittee! One year after final restoration of the work pending the approval of the County Engineer, the guarantee shall be returned to the permittee. However, should the County Engineer, upon final inspection, determine that the construction under this permit was unsatisfactory and/or otherwise in violation of the approved plans or conditions attached to the permit and should the permittee, upon receipt of written notice of deficiencies fail to remedy the same in 30 days, then the County Engineer shall initiate the

BOARD OF CHOSEN FREEHOLDERS  
COUNTY OF HUDSON

ORDINANCE

On Motion of Freeholder \_\_\_\_\_  
Seconded by Freeholder \_\_\_\_\_

process to deduct from the permittee's guarantee, all expenses incurred by the County in performing the necessary repairs to remediate the same.

The County Engineer shall have the right to perform borings in the pavement, cut cores in the pavement or to perform other investigations as deemed necessary to confirm that the provisions of the road opening permit have been satisfied. The cost of such investigations shall be billed to the permittee.

The County Engineer may require an extended maintenance period in excess of one year and an additional maintenance guarantee depending upon the nature of the work involved. This additional obligation will be released upon completion of the work and acceptance of the work by the County Engineer.

When a maintenance bond is posted, it shall be executed by the permittee as principle and surety company licensed to do business in the State of New Jersey as surety.

The release of the guarantee shall be also conditioned upon the permittee restoring the surface and any damage to the streets abutting the work site and those streets which had sustained damage through the use of construction equipment and vehicles.

For utility main construction, other or additional conditions may be prescribed by the County. Plans for such projects must have the approval of the County Engineer before a permit may be issued.

IV. REQUIRED NOTIFICATION

The County Engineer shall notify, once a year, public utility providers and municipalities of planned work on County roads. Any work to be done on these roads will have to be done before paving is started. Such notice shall state that no Road Opening Permit shall be issued for openings, cuts or excavations in said County road for a period of five (5) years after the date of paving. The notice shall also notify such permittee that applications for Road Opening Permits, for work to be done prior to such paving shall be submitted promptly in order that the work covered by the permit may be completed before paving.

During said five year period, no permit shall be issued to open, cut or excavate in said County road unless, in the judgement of the County Engineer, an emergency exists which makes it absolutely essential that the Road Opening Permit be issued.

The County Engineer is authorized to demand a cash escrow or equivalent in an amount not exceeding \$10,000. to assure that any road opening on roadways paved within the past five (5) years, is restored satisfactorily. The restoration shall include milling and repaving of the area so as to blend uniformly with the adjacent roadway as per the conditions stated in the permit, including restoration of

BOARD OF CHOSEN FREEHOLDERS  
COUNTY OF HUDSON

ORDINANCE

On Motion of Freeholder \_\_\_\_\_  
Seconded by Freeholder \_\_\_\_\_

pavement markings, signage and all other appurtenances.

V. BRIDGE CROSSING PROVISIONS

Wherever it is necessary to cross over, through or under existing bridges, viaducts or culverts under the jurisdiction of the County, plans must be filed with the County Engineer which will outline in detail the proposed method of crossing such structures. No work of any kind whatsoever shall be performed until the said supplemental plans have been approved by the County Engineer.

The permittee shall apply and secure all applicable permits from federal, state and local agencies and copies shall be forwarded to the County Engineer together with the application.

IV. WORK SITE SAFETY PROVISIONS AND GUARANTEES

The construction on the County roads pursuant to this Ordinance shall conform to the most recent design standards, plans, details, specifications, method of construction and traffic control.

All permits issued under the section shall be subject to the following rules and regulations. All work shall be conducted within a work zone and conforming to the latest edition of "Manual of Uniform Traffic Control Devices" as published by USDOT FHWA.

A. Safety

1. All work shall be conducted in such a manner as to cause the least public inconvenience and to permit the use of the sidewalk by the pedestrians, the roadway, by vehicles and the flow of water in the gutters. All openings, digging, excavation, piles of material, equipment, machinery, barricades or obstructions, including earth and stone, removed from excavation, shall be removed immediately or properly guarded at all times to prevent accidents. All traffic control devices and their use shall be conforming to the latest edition of the "Manual on Uniform Traffic Control Devices" and must be properly maintained during the construction.
2. The work area shall be made passable to all emergency vehicles during all phases of the work.
3. In the event that the work requires the detour of the vehicular traffic, the permittee shall submit a detour plan for review and approval by the County Engineer, who at the sole discretion, may require the approval of the municipalities involved prior to any road closings. The detour signage must be properly installed and maintained. Any damage to the detour route must

BOARD OF CHOSEN FREEHOLDERS  
COUNTY OF HUDSON

ORDINANCE

On Motion of Freeholder \_\_\_\_\_  
Seconded by Freeholder \_\_\_\_\_

(15)

be corrected by the permittee.

4. If any sidewalk is blocked by any work, a temporary sidewalk shall be constructed or provided, which shall be safe for travel and convenient for users.
- B. All existing pavements, road surfaces, pavement markings, signs, sidewalks, curbs, gutters, pipes, manholes, drains, conduits or other installation or fixtures and property damaged or destroyed by permittee's activity, shall be corrected by the permittee.
- C. No person shall divert or discharge water into, upon or across any County road or sidewalk so that a nuisance is created, or a hazardous condition is caused to exist, or cause the adjacent pavement to be damaged.
- D. It shall be unlawful to make any such excavation, or tunnel, in any way contrary to or at variance with the terms of the permit thereof. Proper bracing shall be maintained to prevent the collapse of adjoining ground and protection of the workers shall be in accordance with the regulations of the New Jersey Department of Labor and Industry and the Occupational Safety and Health Administration. The permittee shall assign supervising personnel to be responsible for the work safety on the project, performed under the "Road Opening Permit".
- E. No injury shall be done to any pipes, cables, conduits or other facilities during the work performed under the Road Opening Permit. Notice shall be given beforehand to the utility company maintaining any such pipes, cables or conduits as prescribed by law.

The permittee shall not proceed with any road opening until he submits to the County Engineer the proof of notification to all utilities.

All work by the permittee shall be done in accordance with the provisions of N.J.S.A. 34:6-47.1 et seq, N.J.A.C. 12:186 and in accordance with the provisions of the Federal Occupational Safety and Health Act of 1970 and of subpart N, paragraph 1926.550 of the rules and regulations issued under said acts.

It is the sole responsibility and duty of permittee to make such an investigation and effort to locate all utilities. Issuance of the permit by the County does not approve or disapprove the locations of the same. The County shall not be held responsible for any damage to any utilities, underground or overhead.



BOARD OF CHOSEN FREEHOLDERS  
COUNTY OF HUDSON

ORDINANCE

On Motion of Freeholder \_\_\_\_\_  
Seconded by Freeholder \_\_\_\_\_

- F. The permittee shall clean up and remove promptly and continuously from the work site, all excavated material and debris and upon final completion of the project shall leave the site of work in a neat and orderly condition as good as it was previously.

Where topsoil, seeded areas, sod or landscaping, is disturbed in the course of the work, the permittee shall restore such ground surfaces to a condition equal to that prior to commencement of work.

- G. If permittee shall fail to comply with the rules and regulations as provided in this ordinance after receipt of written notice, then the County reserves the right to take any action to insure compliance with this ordinance. In that event, the permittee shall be charged with the cost of same at a rate determined by the County Engineer based on current contract rates, if such are in effect, or a schedule of costs accepted by the County Engineer, based on the rates as published by NJDOT or the actual cost of repairs paid to contractor selected by the County plus 15% overhead. Any monies due to the County in excess of the permit fee shall be billed upon completion of the work and shall be paid by the permittee within thirty (30) days after the receipt of the bill. Failure to pay such dues shall result in the permittee paying the maximum interest rate allowed bylaw, as well as any attorney's fees and costs incurred by the County in furtherance of the collection of said monies.

The County Engineer shall also have the authority to deny all future permits until differences identified as above are corrected to the satisfaction of the County Engineer.

The County shall not be liable for damages for any personal injuries or damage to property sustained as the result of any excavation or opening in any street, bridge or curb work made by any person by virtue of the provisions of this chapter.

Neither the County nor any of its' employees shall be deemed to be the agent or the servant of the permittee for any of the purposes of this section.

V. INSURANCE REQUIREMENTS

- A. The permittee shall provide insurance as follows: The work shall not commence until all insurance as required under the following subparagraphs is submitted and until such insurances have been approved by the county, nor shall the permittee allow any of his subcontractors to commence work on his subcontract until all similar insurances required have been obtained and approved.
- B. The permittee shall take out and maintain during the work under the permit, Workmen's Compensation

BOARD OF CHOSEN FREEHOLDERS  
COUNTY OF HUDSON

ORDINANCE

No.

On Motion of Freeholder \_\_\_\_\_  
Seconded by Freeholder \_\_\_\_\_

Insurance for all his employees at the site of the project and in case any work is sublet, the permittee shall require the subcontractor similarly to provide Workmen's Compensation Insurance for all the latter's employees unless such employees are covered by the protection afforded by the permittee. In case any class of employees engaged in hazardous work under this permit at the site of the project is not protected under the Workmen's Compensation statutes, the permittee shall provide and shall cause each subcontractor to provided by the Workmen's Compensation statute for the protection of his employees not otherwise protected.

- C. The permittee shall obtain and keep in force during the work under the permit, public liability and property damage insurance in companies and in form to be approved by the County. Said insurance shall provide coverage to the permittee, any subcontractor performing work provided by this permittee, and the County. The County, its officers, agents, servants and employees as their interest may appear, shall be named as additional insured on said policy insofar as the work and obligations performed under the permit concerned. The coverage so provided shall protect against claims for personal injuries, including accidental death, as well as claims for property damages which may arise from any act or omission of the County, the permittee or the subcontractor or by anyone directly employed by either of them. The minimum policy limits of such insurance shall be as follows:

1. Bodily injury liability coverage with limits of not less than One Million Dollars (\$1,000,000.) for bodily injury, including accidental death, to any one person, and subject to that limit for each person, in an amount not less than One Million Dollars (\$1,000,000.) for each accident; and property damage coverage in an amount of not less than Five Hundred Thousand Dollars (\$500,000.) for each accident.

- D. A copy of the insurance policy, together with a copy of the endorsements naming the County, its officers, agents, servants and employees as their interest may appear, as an additional insured, shall be provided to the County before issuance of the permit.

- E. The permittee agrees to save the County, its officers, agents, servants and employees from all lost or damage occasioned to it or to any third person or property by reason of any carelessness or negligence on the part of the permittee, subcontractor, agents and employees in the performance of the work under the permit, and will, after reasonable notice thereof, defend and pay the expense of defending any suit which may be commenced against the County, its officers, agents, servants

BOARD OF CHOSEN FREEHOLDERS  
COUNTY OF HUDSON

ORDINANCE

No.

On Motion of Freeholder \_\_\_\_\_  
Seconded by Freeholder \_\_\_\_\_

and employees as their interest may appear, by the third person alleging injury by reason of such carelessness or negligence, and will pay any judgement which may be obtained against the County, its officers, agents, servants and employees as their interest may appear in such suit. The permittee shall furnish the insurance required.

D. Automobile and truck insurance, covering vehicles owned and/or operated by the permittee and vehicles operated for the permittee, including those employees when so operated, shall be provided as follows:

1. One person in any one accident - amount of One Million Dollars (\$1,000,000.)
2. Two or more persons in any one accident - amount of Three Million Dollars (\$3,000,000.)
3. Property damage in any one accident - amount of Five Hundred Thousand Dollars (\$500,000.) with aggregate property damage policy limit of One Million Dollars (\$1,000,000.)

E. Worker's Compensation

VI. WORK SITE RESTORATION

Immediately after the work is performed for which the permit had been issued, road repair and backfilling shall be done in accordance with details prepared by the County Engineer which accompanied the permit. Excavated material shall not be used as backfill unless approved by the County Engineer. Temporary pavement or patch work shall be removed approximately one month after installation and the opening shall be restored to the grade, slope and profile that prevailed at the time of the opening or as directed by the County Engineer. Pavement markings shall be restored on any roadway or it's portion before it's opening to traffic.

VII. NOTIFICATION AND PROGRESS OF THE WORK

The permittee shall notify the County Engineer in writing at least forty-eight (48) hours in advance of any activity and likewise, at the completion of the activity or project.

Failure to provide such notification may result in cancellation of the permit. The permittee shall keep a copy of the permit at the site at all times. The permittee shall retain full responsibility for any damages which may result from any construction activity notwithstanding any approvals from the County Engineer.

All work required to be done shall be completed within the time specified in the permit. Trenches shall not be kept open when work is not in progress. If work is stopped for more than 24 hours, the trench shall be temporarily backfilled and capped with a temporary pavement. The

BOARD OF CHOSEN FREEHOLDERS  
COUNTY OF HUDSON

ORDINANCE

No.

On Motion of Freeholder \_\_\_\_\_

Seconded by Freeholder \_\_\_\_\_

validity of a permit may be extended, if so requested, in writing by permittee prior to the expiration period thereof for such additional periods as determined by the County Engineer.

VIII. EMERGENCY SITUATIONS

In the event of any emergency in which a sewer, main, conduit or utility in or under any road breaks, bursts or otherwise is in such condition as to immediately endanger the property, life, health or safety of any individual, the person, company or utility owning or controlling such sewer, main, conduit or utility, without first applying for and obtaining an excavation permit hereunder, shall immediately take proper emergency measures to secure or remedy the dangerous conditions for the protection of property, life, health and safety of individuals. However, such person owning or controlling such a facility shall apply for a permit not later than the end of the next business day and shall not proceed with permanent repairs without first obtaining a permit hereunder.

IX. FAILURE TO PROGRESS THE WORK

Where the permittee is not making progress satisfactory to the County Engineer or violates any provision of the permit, the County Government hereby authorizes the County Engineer or his authorized agent to revoke the permit and to remedy the work of the permittee. Written notice shall be given by the County Engineer of intent to take such action. The permittee shall complete proposed construction within the time specified in the permit. If not done within this time and if no extension has been obtained, such failure to complete shall be deemed a violation.

X. MAINTENANCE OF TRAFFIC FLOW

The permittee shall maintain vehicular and pedestrian traffic in the work area as per conditions stated in the permit.

The permittee shall backfill all excavated areas within the roadway to a grade compatible with the existing traveled way at such time he is not actively working. This shall include nights, weekends and periods of shut down. Trenches shall not remain open overnight under any circumstances. The work area must be maintained at all times in a safe and neat condition.

Roadways, shoulders and sidewalks in areas which the permittee has actually commenced construction operations and which are reserved for vehicular and pedestrian traffic shall be maintained by the permittee, at his expense, free from obstructions and in a smooth riding or walking condition at all times, including seasonal shutdowns.

If the excavation extends the full width of the County road, only one-half of the road shall be excavated at one time and shall be backfilled and a temporary pavement placed before the other half is excavated, unless otherwise

BOARD OF CHOSEN FREEHOLDERS  
COUNTY OF HUDSON

ORDINANCE

No. \_\_\_\_\_

On Motion of Freeholder \_\_\_\_\_  
Seconded by Freeholder \_\_\_\_\_

permitted by the permit. Where considered necessary, work under a permit shall be carried on only within such hours as allotted by the County Engineer. If work cannot be completed within the time specified, open trenches shall be backfilled or covered with steel plates of sufficient strength to carry all traffic safely. Plates must be recessed and pinned and can only be left out with the approval of the County Engineer. If, in his judgement, traffic conditions, the safety or convenience of the traveling public or the public interest requires that the excavation work be performed as emergency work, the County Engineer shall have full power to order, at the time the permit is granted, that a crew of workers and adequate facilities be employed by the permittee twenty-four (24) hours a day to the end that such excavation work may be completed as soon as possible. The County Engineer shall also have full power to limit the hours of work as the public interest may require.

XI. MISCELLANEOUS REQUIREMENTS

Each permittee shall conduct and carry out the work in such a manner as to avoid unnecessary inconvenience and annoyance to the general public and occupants of neighboring property. The permittee shall take appropriate measures to reduce to the fullest extent practicable in the performance of the excavation work, noise, dust and unsightly debris.

Users of subsurface street space shall maintain accurate drawings and plans, showing the location and character of all underground structures including abandoned installations. Said drawings and plans are to be kept on file in the office of said users and shall at all times be available to the County Engineer.

XII. ORDINANCE NOT APPLICABLE TO COUNTY WORK

The provisions of this ordinance shall not be applicable to any work under the direction of the County, by employees of the County or by any contractor of the County performing work for and on behalf of the County necessitating openings or excavations in County roads, curbs or bridges.

XIII. WORK BY MUNICIPALITIES AND GOVERNMENTAL AGENCIES

Any work done by municipalities, governmental agencies, their departments and divisions, must be performed under the provisions of this ordinance except that the County may waive the fee.

XIV. LIABILITY OF COUNTY

This ordinance shall not be construed as imposing upon the County or any official or employees, any liability or responsibility for damages to any person injured by the performance of any excavation work for which an excavation permit is issued hereunder, nor shall the County or employee thereof be deemed to have assumed any such liability or responsibility by reason of inspections authorized hereunder, the issuance of any permit or the approval of any excavation work.

BOARD OF CHOSEN FREEHOLDERS  
COUNTY OF HUDSON

ORDINANCE

No. \_\_\_\_\_

On Motion of Freeholder \_\_\_\_\_  
Seconded by Freeholder \_\_\_\_\_

XV. PENALTIES

Any person, firm or corporation violating any of the provisions of this ordinance shall be deemed guilty as a disorderly person and upon conviction thereof in a court of competent jurisdiction, shall be fined or be imprisoned as prescribed by the law. Each day such violation is committed or permitted to continue shall constitute a separate offense and shall be punishable as such hereunder.

FEE SCHEDULE

ROAD OPENING PERMITS

Application Fee		
Normal	\$10.00	---
Non-reported Opening	\$100.00	---
Permit Fee (Opening Size)		
Up to 20 S.F.	\$20.00	---
Between 20 and 80 S.F.	\$100.00	
Additional over 80 S.F.	\$0.50/S.F.	
Multiple Openings (Minimum)	\$20.00 EACH	
Guarantee Bond or Check		
Up to 20 S.F.	\$500.	-
Over 20 S.F.	\$500. plus \$20. per	
	S.F. over 20 S.F.	
Multiple Openings (Minimum)	\$500. Each	
Newly Paved Roads (5 Yrs or less)	\$0.00 - \$10,000. as	
	determined by	
	County Engineer	-

CURB PERMITS

Application Fee	\$10.00
Permit Fee	
Depressed Curb (Driveway Opening)	\$1.00/L.F. (\$20. minimum)
Full Height Curb	\$0.50/L.F. (\$20. minimum)
Guarantee Bond or Check	
Single Driveway	\$10.00/L.F.
All Others	\$10.00/L.F.

BRIDGE PERMITS

Application Fee	\$30.00
Permit Fee	
All Work within 10' of Bridge	\$250.00
Outside these limits	Same as Road Opening Fee above
Guarantee Bond or Check	
All Work within 10' of Bridge	\$5,000.00
Outside of these limits	Same as Road Opening Fee above

BOARD OF FREEHOLDERS  
COUNTY OF HUDSON

ORDINANCE

No. \_\_\_\_\_

On Motion of Freeholder \_\_\_\_\_  
Seconded by Freeholder \_\_\_\_\_

This Ordinance shall take effect in the manner prescribed by law.

Freeholder	Aye	Nay	Abst.	N.P.	Freeholder	Aye	Nay	Abst.	N.P.
Ascolese	X				Colon	X			
Braker	X				Cruz	X			
Carroll	X				Fitzgibbons	X			
Cifelli	X				O'Dea	X			
Chairman Vega	X								

APPROVED AS TO LEGAL FORM

BY: M.E. Howell  
FRANCIS De LEONARDIS  
HUDSON COUNTY COUNSEL

It is hereby certified that at a regular meeting of the Board of Freeholders of the County of Hudson held on the 25 day of February A.D. 1999, the foregoing ordinance was finally adopted with 9 members voting in the affirmative and 0 in the negative.

Jan A. Spence, Clerk

The foregoing ordinance having been duly presented to me, hereby \_\_\_\_\_ the same

Dated: A.D., 1999

[Signature]  
County Executive

JG, RU, IS,  
BG, AS

**BOARD OF CHOSEN FREEHOLDERS  
COUNTY OF HUDSON  
ORDINANCE**

No. 529-9-2016

On Motion of Freeholder O'Dea  
Seconded by Freeholder Romanu

**AN ORDINANCE AMENDING ORDINANCE NUMBER 116-2-1999**

**REGARDING THE RULES AND REGULATIONS**

**GOVERNING ROAD OPENING PERMITS**

**WHEREAS**, Ordinance Number 116-2-1999 established the rules and regulations governing road opening permits; and

**WHEREAS**, upon further review and inspection by the County Engineer it has been discovered that the Ordinance should be amended to require contractors working on County roadways to restore the roadways from "curb to curb;" and

**WHEREAS**, it is in the best interest of the County to ensure that roadways are re-paved and restored "curb to curb" for the safety and welfare of motorists on County roadways.

**NOW, THEREFORE, BE IT ORDAINED** by the Board of Chosen Freeholders of the County of Hudson that:

1. The above recitals are incorporated herein as though fully set forth at length.
2. Ordinance Number 116-2-1999 is, by this Act, amended to reflect the following:

**Sections I through V** – No change.

**Section VI. Work Site Restoration:** (delete the existing language and add the following language):

The following will be required for work performed within a County Road that has been paved within the last five years.

A. If it is necessary to open a street that has been paved within the last five years from the date of the permit application then it is required that the permittee shall complete final pavement restoration from curb to curb (or, the full width of the road) to a distance of approximately 100 feet around the area of the openings.

B. The distances in either direction of the opening will be determined by the County Engineer based on the proximity to other roadways or utility concerns. In most cases, final pavement restoration will encompass 50 feet in both directions of the opening for a full width of the existing road. The County Engineer may allow resurfacing to the center line of the road only if the opening is completed within one lane and does not involve disturbance across the center line.

C. Temporary and final pavement restoration shall be completed in accordance with County standards, and milling will entail the full length and width of the area that must be repaved.

D. The restoration of the pavement shall be done no fewer than 60 days after the opening and no more than 120 days after the opening. This will allow for any settlement in the trench to take place before the final pavement is placed. Exceptions to this time frame may be allowed by the County Engineer dependent upon the time of year, which can affect the availability of paving materials.



E. For roadways that have not been paved in the last five years, immediately after the work is performed for which the permit had been issued road repair and backfilling shall be done in accordance with details prepared by the County Engineer, which accompanied the permit. Excavated material shall not be used as backfill unless approved by the County Engineer. Temporary pavement or patch work shall be removed approximately one month after installation and the opening shall be restored to the grade, slope, and profile that prevailed at the time of the opening or as directed by the County Engineer. Pavement markings shall be restored on any roadway or its portion before its re-opening to traffic.

F. All pavement markings shall be restored on any roadway or its portion before its re-opening to traffic.

**Sections VII to XV – No change.**

**Fee Schedule:** (existing section is deleted and replaced with the following language):

**ROAD OPENING PERMITS**

**Application Fee:**

Normal:	\$50.00
Non-reported Opening:	\$200.00

**Permit Fee:**

(Based on Opening Size)

Up to 20 sq ft	\$100.00
Between 20 & 80 sq ft	\$250.00
Additional over 80 sq ft	\$1.00 per sq ft
Multiple openings (min.)	\$ 100.00 ea.

**Road Opening Performance Bond:**

Up to 20 sq ft	\$5,000.00 (min.)
Over 20 sq ft	\$5,000.00 plus \$20.00 per sq ft over 20 sq ft
Multiple Openings (min.)	\$5,000.00 each
Newly Paved Roads (5 years or fewer)	\$50,000.00, or as determined by the County Engineer

**Curb & Driveway Permits:**

Application Fee: \$50.00  
 Permit Fee –  
 Depressed Curb (Driveway Opening)  
 or Full Height Curb: \$1.00/L.F. (\$100.00 min)  
 Guarantee Bond: \$5,000.00 (single driveway)  
 \$10,000.00 (all others)

**Bridge Permits:**

Application Fee: \$100.00  
 Permit Fee: \$500.00  
 Fee for all work within 10 ft of  
 Bridge outside these limits: See road opening permit fee above.  
 Guarantee Bond:  
 (For all work within 10 ft of  
 bridge outside these limits): \$25,000.00, or as determined by the  
 County Engineer

3. This Ordinance shall take effect in the manner prescribed by law.

Freeholder	Aye	Nay	Abst	N.P	Freeholder	Aye	Nay	Abst	N.P.
Balmir	/				Rodriguez	/			
Cifelli	/				Romano	/			
Kopacz	/				Vainieri	/			
Maldonado	/				Chairperson Rivas	/			
O'Dea	/								

It is hereby certified that at a regular meeting of the Board of Freeholders of the County of Hudson held on the 8 day of Sept A.D. 2016, the foregoing Ordinance was finally adopted with 9 members voting in the affirmative and 0 in the negative.

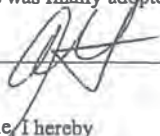
 Clerk

The foregoing Ordinance having been duly presented to me, I hereby \_\_\_\_\_ the same

Dated: A.D. 2016

\_\_\_\_\_  
 County Executive

JM

**BOARD OF CHOSEN FREEHOLDERS**

**COUNTY OF HUDSON  
ORDINANCE**

No.: 405-6-2017

On Motion of Freeholder O'Dea .  
Seconded by Freeholder Vannier

**AN ORDINANCE AMENDING ORDINANCE NUMBER 116-2-1999  
REGARDING THE RULES AND REGULATIONS  
GOVERNING ROAD OPENING PERMITS**

**WHEREAS**, Ordinance Number 116-2-1999 established the rules and regulations governing road opening permits; and

**WHEREAS**, upon further review and inspection by the County of Hudson, it has been discovered that a need exists to define emergency situations, and to impose penalties for any work performed under the characterization of an emergency that is not, in fact, an emergency; and

**WHEREAS**, it is in the best interest of the County to ensure that this definition is established and these rules followed.

**NOW, THEREFORE, BE IT ORDAINED** by the Board of Chosen Freeholders of the County of Hudson that:

1. The above recitals are incorporated herein as though fully set forth at length.
2. Ordinance Number 116-2-1999 is, by this Act, amended to reflect the following:

**Sections I through VII – No Change.**

(add the following language)

**Section VIII. Emergency Situations.**

(existing section deleted)

Add the following language:

A. Emergency shall be defined as a situation affecting the public health, safety or welfare and that requires immediate attention, or is of such a nature that a delay in performing the services will result in substantial property damage or the delay in providing essential utility services to the general public.

B. Work performed pursuant to an emergency may be performed without obtaining a permit as more fully described herein. However, in the event of an emergency, before performing work the contractor or public utility must:

- Immediately contact the Hudson County engineer and advise the County of the nature of the emergency and the anticipated scope of work to remediate the emergency; and
- within twenty four (24) hours apply for a road opening permit as fully set forth in this section.

**BOARD OF CHOSEN FREEHOLDERS  
COUNTY OF HUDSON**

**ORDINANCE**

**No.:**

**On Motion Of Freeholder  
Seconded by Freeholder**

C. The County Engineer shall provide notice to the Mayor and the Freeholder of the district in which the emergency has arisen via telephone call, fax, or email, as soon as is practicable under the circumstances.

D. Any contractor or public utility that is found to have characterized a situation as an emergency that is later discovered to have not been an immediate danger to the health, safety, or welfare of the public shall be subject to the following penalties:

\$1,000.00 per day for the first violation;

\$1,500.00 per day for the second violation;

\$2,000.00 per day for the third violation.

3. This Ordinance shall take effect in the manner prescribes by law.

Freeholder	Aye	Nay	Abst	N.P.	Freeholder	Aye	Nay	Abst.	N.P.
Balmir	✓				Rivas	✓			
Cifelli	✓				Rodriguez	✓			
Kopacz				✓	Romano	✓			
Maldonado	✓				Chairperson Vainieri	✓			
O'Dea	✓								

It is hereby certified that at a regular meeting of the Board of Freeholders of the County of Hudson held on the 20 day of June A.D. 2017, the foregoing Ordinance was introduced with members 8 voting in the affirmative and 0 in the negative.

 Clerk

**APPROVED AS TO LEGAL FORM**

**BY:  
DONATO J. BATTISTA  
HUDSON COUNTY COUNSEL**

Source: Law  
DJD/ek

COUNTY OF HUDSON



**OFFICE OF  
THE COUNTY EXECUTIVE**

**BRENNAN COURT HOUSE  
583 NEWARK AVENUE  
JERSEY CITY, NEW JERSEY 07306  
PHONE: 201-795-6200  
FAX: 201-714-4825**

**THOMAS A. DE GISE  
COUNTY EXECUTIVE**

June 29, 2017

Alberto Santos, Clerk  
Hudson County Board of Chosen Freeholders  
567 Pavonia Avenue  
Jersey City, New Jersey 07306

RE: Executive Order No. TAD -67  
Notice to be provided to County Executive and  
Board of Chosen Freeholders Upon Application of  
Road Permit.

Dear Mr. Santos:

Pursuant to the authority and duties of the County Executive announced in Section N.J.S.A. 40:41A-36 (d) of the County Executive Form of Optional County Charter Law, relative to the duty to supervise the care and custody of all County property to please be advised of the following Executive Order:

**WHEREAS**, Ordinance Number 116-2-1999 sets forth the "Rules and Regulations Governing Road Opening Permits"; and

**WHEREAS**, upon consultation with the County Department of Roads and Public Property, and the Board of Chosen Freeholders, it is anticipated that such road openings often cause traffic delays and other service interruptions to the municipalities, towns, and townships in which road work is to be performed; and

**WHEREAS**, such interruptions could be mitigated if proper notice is provided to the elected officials in whose districts work is anticipated, further enhancing the health, safety, and welfare of pedestrians and motorists on those roadways.

**NOW, THEREFORE, I, THOMAS A. DEGISE**, as County Executive do hereby ORDER and DIRECT as follows:

1. The aforesaid recitals are incorporated herein as though fully set forth at length.
2. Upon application by a contractor to the County Engineer for any road opening permit, the County Engineer shall provide notice of such application to the Mayor and Freeholder in the district in which the road opening shall take place via fax, email, telephone call, or any other form of communication deemed appropriate to convey the information.
3. Elected officials shall have three (3) days in which to bring to the attention of the County Engineer any reasonably foreseeable delays that shall be incurred by the granting of such permit.
4. Upon that information the County Engineer shall approve or deny the permit, or, in the alternative, re-schedule the work to be performed.
5. Any work being performed pursuant to an emergency shall be communicated as soon as is practicable under the circumstances.
6. The Clerk of this Board shall forward a certified copy of this Executive Order to the Municipal Clerks of all Hudson County Municipalities.
7. This Executive Order shall remain in place until rescinded.

Respectfully Submitted,  
  
Thomas A. DeGise  
Hudson County Executive

TAD:mm

cc: Honorable Anthony Vainieri, Chairperson, Board of Chosen Freeholders  
Abraham Antun, County Administrator  
David Drumeler, Deputy County Administrator  
Denise D'Alessandro, Director of Roads and Public Property

Address: \_\_\_\_\_

Permit No.: \_\_\_\_\_

Applicant: \_\_\_\_\_

Date: \_\_\_\_\_

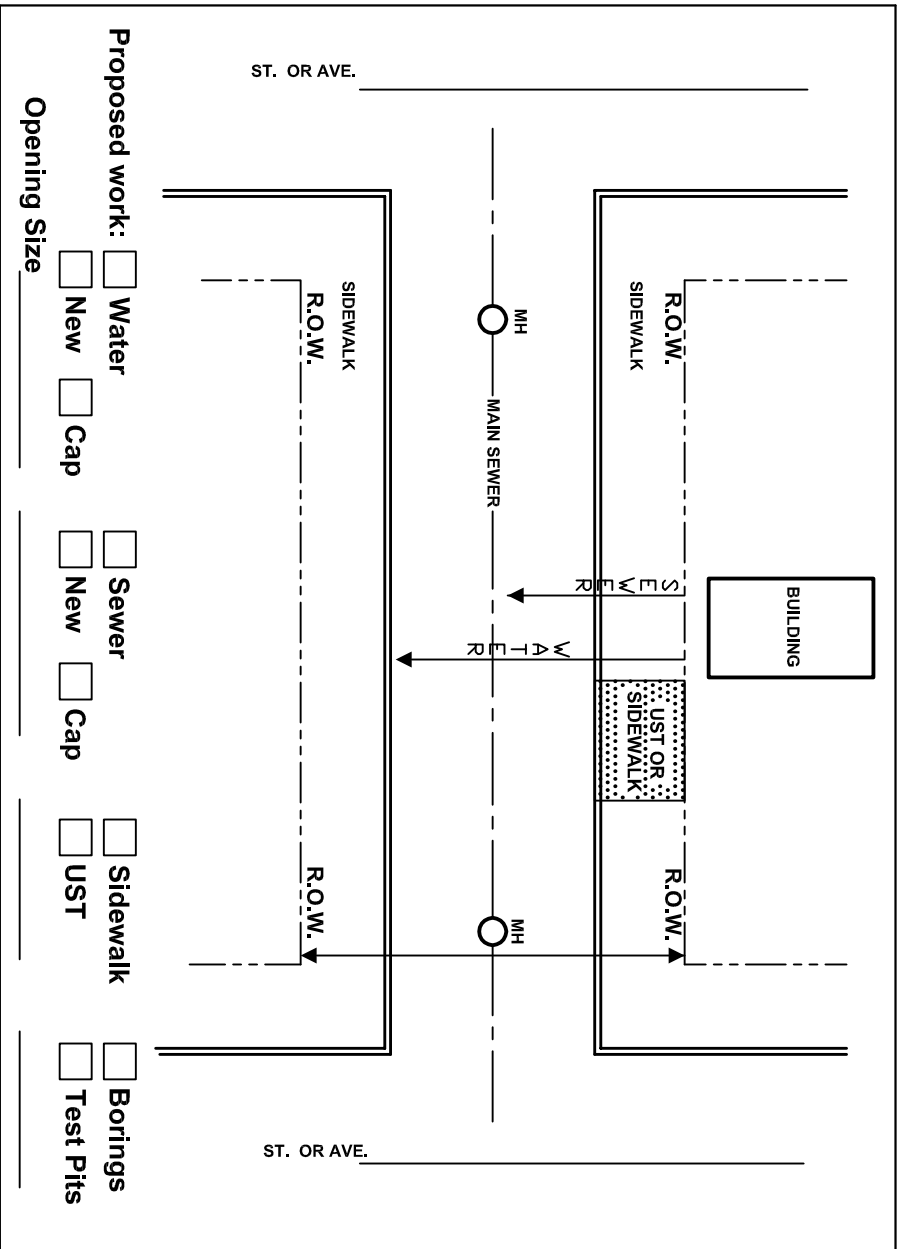

- Proposed work:  Water  Sewer  Sidewalk  Borings  
 New  Cap  New  Cap  UST  Test Pits
- Opening Size \_\_\_\_\_

INSPECTOR: \_\_\_\_\_ Date: \_\_\_\_\_  Approved  Disapproved

COMMENTS: \_\_\_\_\_

\_\_\_\_\_

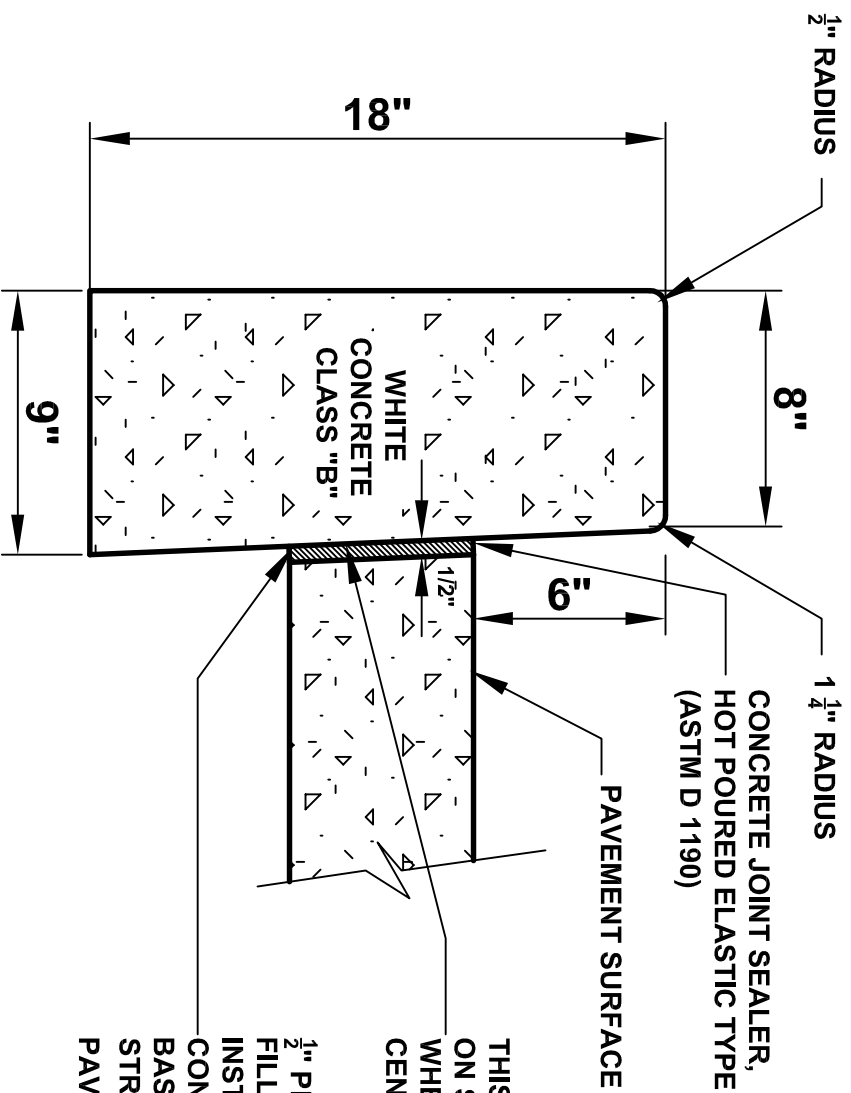

1/2" RADIUS

8"

1/4" RADIUS

CONCRETE JOINT SEALER,  
HOT Poured ELASTIC TYPE  
(ASTM D 1190)

PAVEMENT SURFACE

THIS FACE MAY BE CONSTRUCTED ON SAME BATTER AS UPPER FACE WHEN CURB IS CONSTRUCTED ADJACENT TO BITUMINOUS PAVEMENT.

1/2" PREFORMED EXPANSION JOINT FILLER, BITUMINOUS TYPE, TO BE INSTALLED BETWEEN CURB AND CONCRETE PAVEMENT OR CONCRETE BASE COURSE. DEPTH OF JOINT FILLER STRIP EQUAL TO THE THICKNESS OF THE PAVEMENT LESS 1/2".

**NOTES:**

1. TRANSVERSE 1/2" WIDE SHALL BE INSTALLED IN THE CURB 20'-0" APART AND SHALL BE FILLED WITH PREFORMED BITUMINOUS-IMPREGNATED FIBER JOINT FILLER RECESSED 1/4" IN FROM FRONT FACE AND TOP OF CURB.
2. EXPANSION JOINTS THRU AND ADJACENT TO THE CURB SHALL BE INCLUDED IN THE UNIT PRICE BID FOR CURB.

**WHITE CONCRETE VERTICAL CURB DETAIL**

NOT TO SCALE



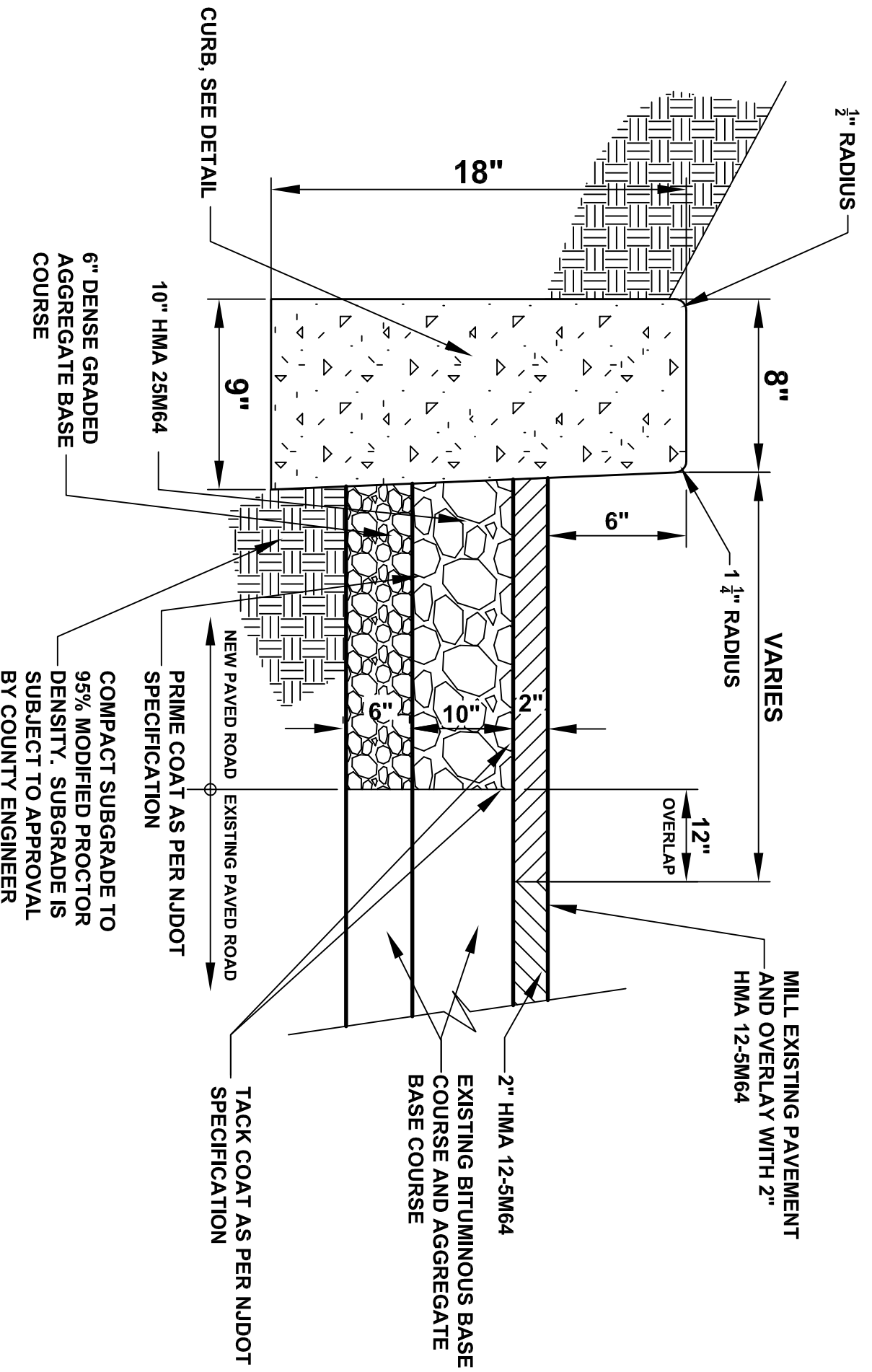

# COUNTY ROAD REPAIR PAVEMENT DETAIL

NOT TO SCALE

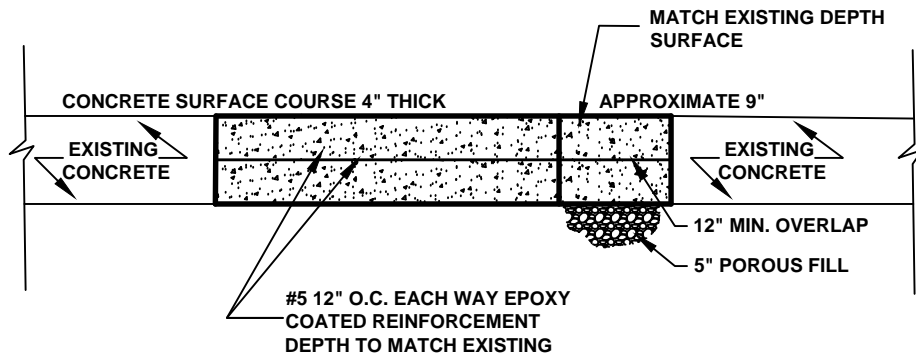

### METHOD OF CONCRETE RECONSTRUCTION

- STEP 1-** CONCRETE TO BE SAWCUT TO DEPTH ABOVE EXISTING REINFORCEMENT AROUND PERIMETER.
- STEP 2-** REMOVE ALL CONCRETE WITHIN SAWCUT AREA.
- STEP 3-** EXISTING STEEL TO BE CUT & REMOVED LEAVING 12" MIN. DOWEL FOR OVERLAP OF NEW REINFORCEMENT.
- STEP 4-** PREPARE UNDER LAYER AND PLACE REINFORCEMENT.
- STEP 5-** CONCRETE SURFACE COURSE 9" THICK.

### PROPOSED CONCRETE RECONSTRUCTION

NOT TO SCALE

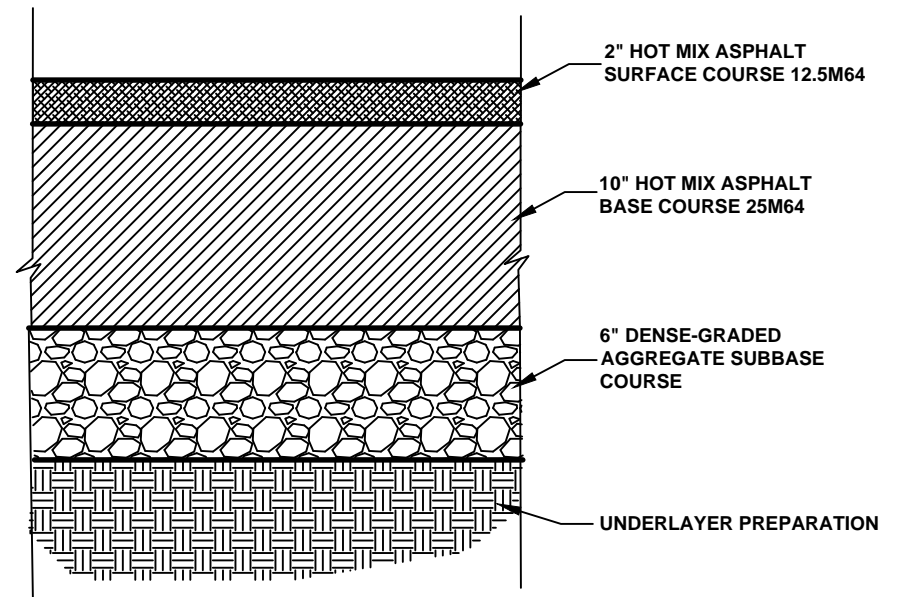

### PAVEMENT RECONSTRUCTION DETAIL

NOT TO SCALE TYPICAL SECTION

# CURB PIECE TYPE "N - ECO"

CAMPBELL FOUNDRY or APPROVED EQUIVALENT

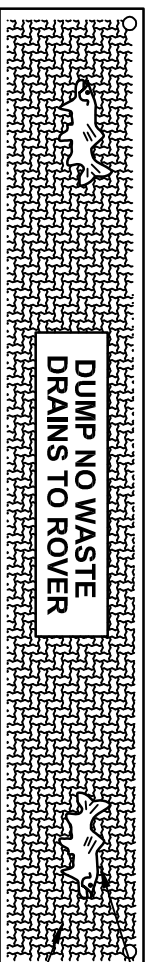

3D BROOK TROUT DESIGN  
 DIAMOND DESIGN  
 SKID-RESISTANT SURFACE

PLAN

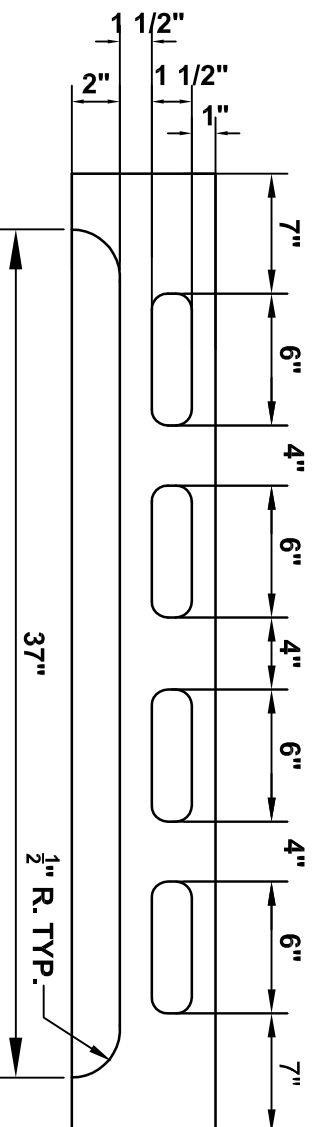

FRONT ELEVATION

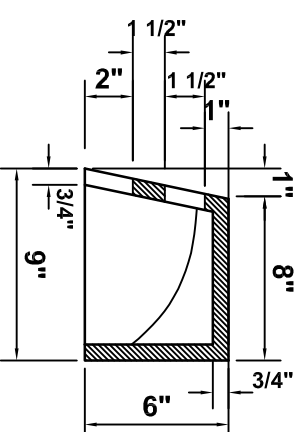

6" HIGH CURB

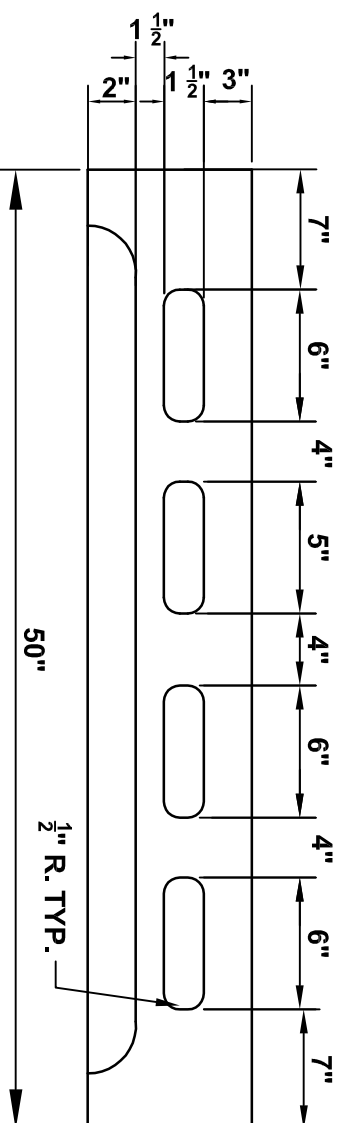

END SECTION

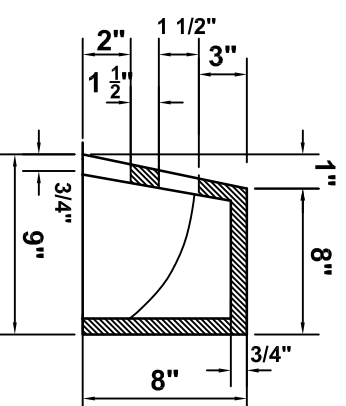

8" HIGH CURB

pen table=\\NDOT\TRNG\Projects\NDOT\Eng\pilot\TBA\Roadway\Detaila\_13x17.tbl  
 scale=63.062882:1.000000  
 date=28-SEP-2016 11:06  
 ID=TP2VLL  
 BDC18D-01-ORIGINAL SHEET

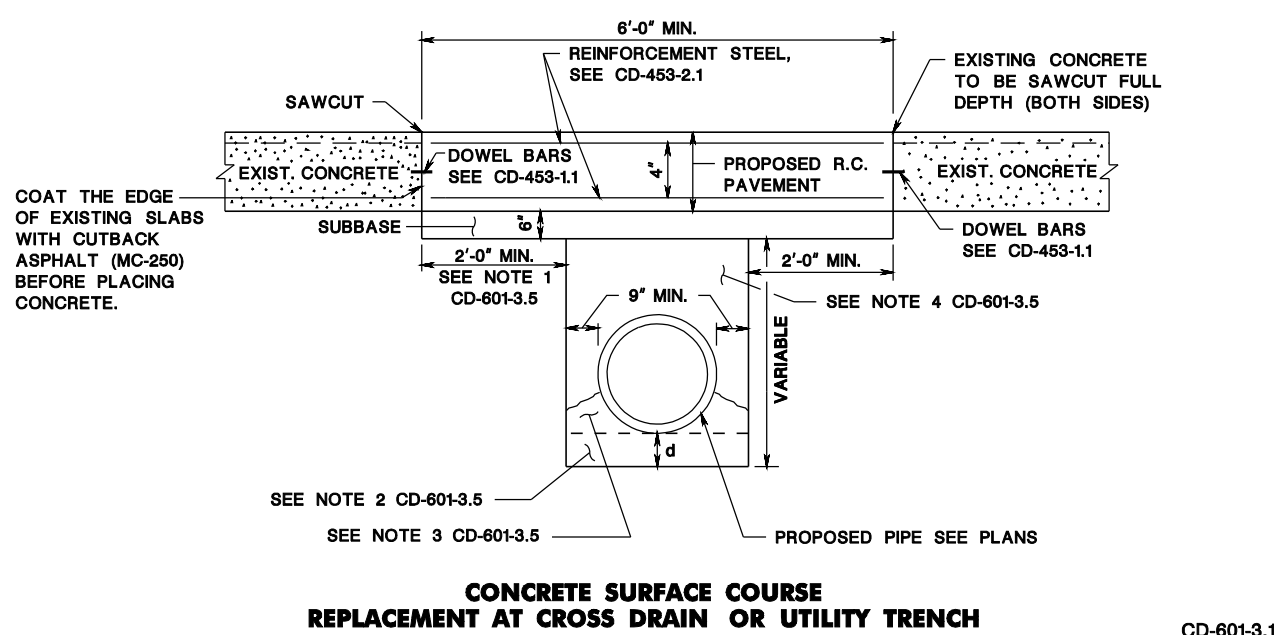

CD-601-3.1

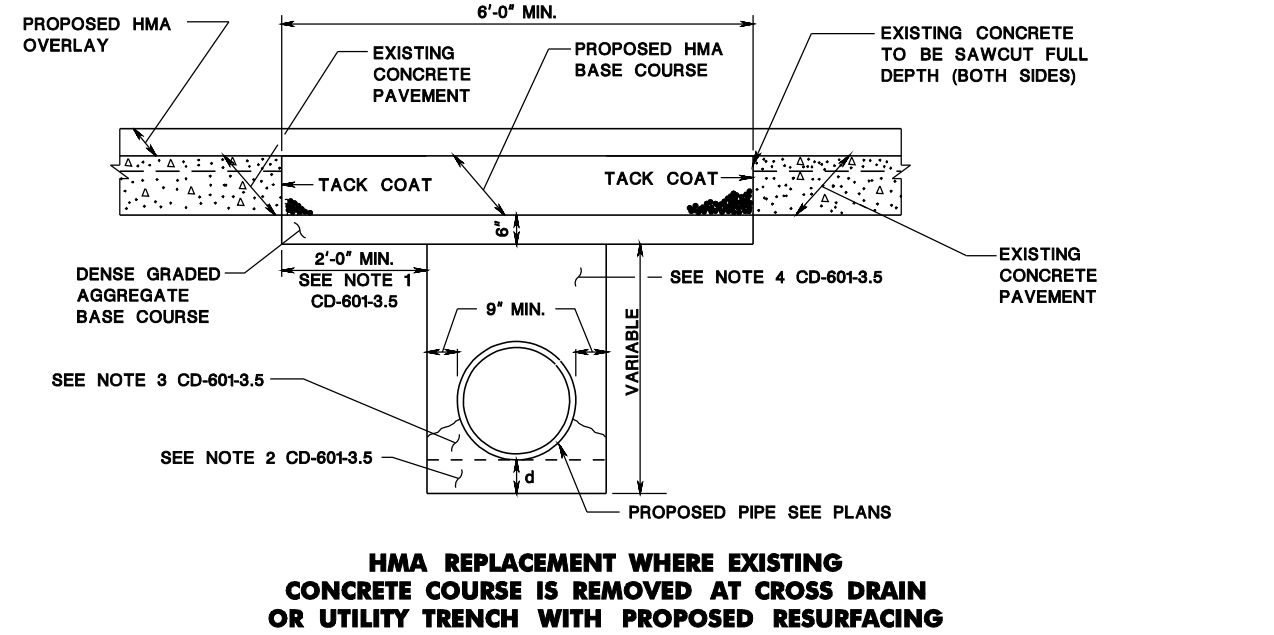

CD-601-3.2

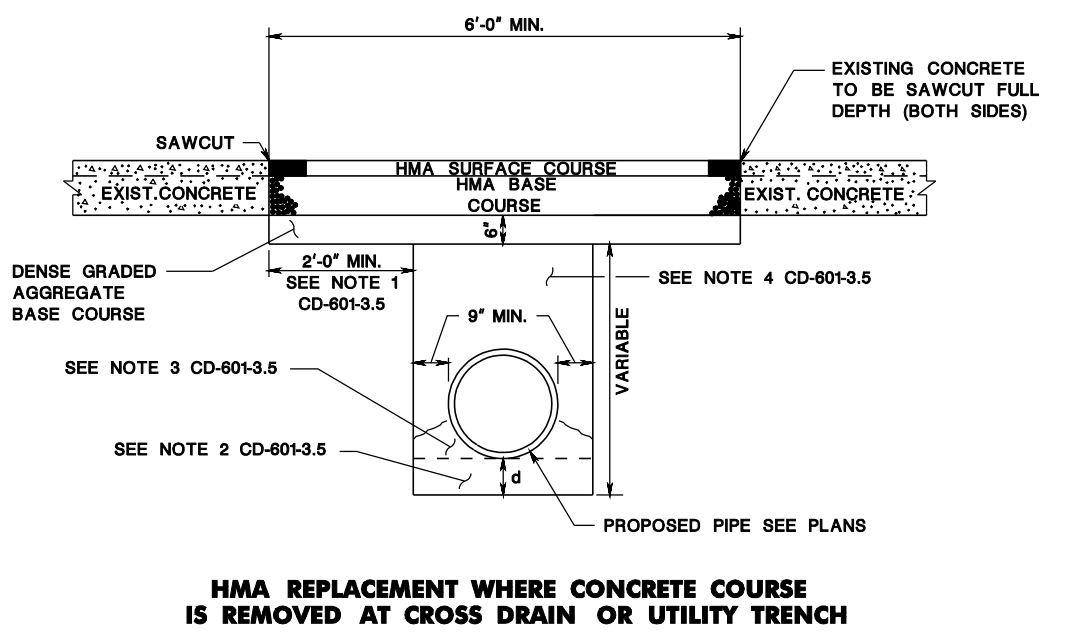

CD-601-3.3

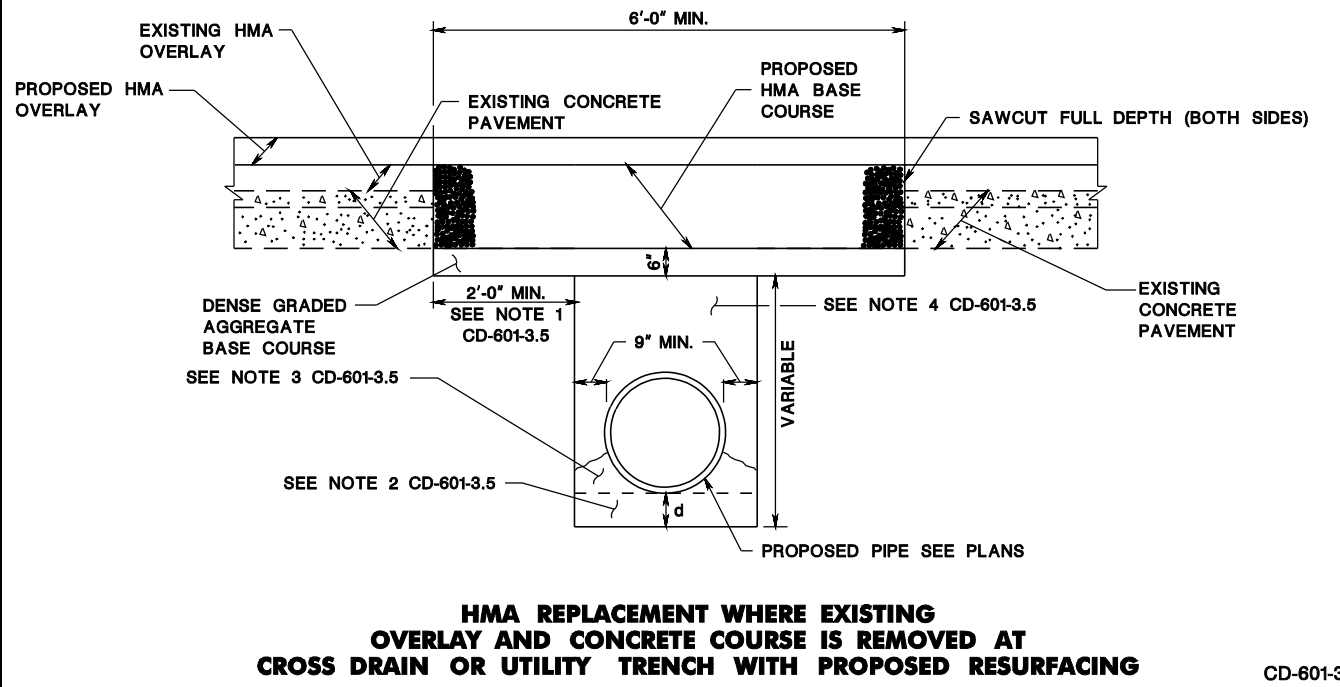

CD-601-3.4

- NOTES:**
- SAWCUT THE EXISTING PAVEMENT A MINIMUM OF 2'-0" FROM THE SIDES OF THE PROPOSED CROSS DRAIN OR UTILITY TRENCH EXCAVATION ON BOTH SIDES.
  - ADDITIONAL EXCAVATION REQUIRED WHEN PIPE BEDDING IS DESIGNATED, OR WHEN ROCK OR OTHER HARD MATERIAL IS ENCOUNTERED.
  - BACKFILL TO BE PLACED SO AS TO ENSURE SUFFICIENT COMPACTION UNDER PIPE HAUNCHES.
  - THE PIPE OR UTILITY TRENCH TO BE BACKFILLED IN ACCORDANCE WITH THE SPECIFICATIONS FOR BACKFILLING OR WITH AGGREGATE, DESIGNATION I-1, I-2, I-3, OR I-13. ENSURE THE WIDTH IS 36" MINIMUM OR THE OUTSIDE DIAMETER OF THE PIPE PLUS 18".

UNDERLYING SOIL	d MIN.	
	CONC. PIPE	ALUMINUM PIPE OR HDPE PIPE
ROCK OR HARD MATERIAL	6"	12"
OTHER MATERIAL	6"	6"

CD-601-3.5

**CROSS DRAIN OR UTILITY TRENCH CONSTRUCTION**  
 N.T.S.

NEW JERSEY DEPARTMENT OF TRANSPORTATION

**CONSTRUCTION DETAILS**

**NOTE:**  
 REINFORCEMENT STEEL IS IN METRIC UNITS.  
 HMA = HOT MIX ASPHALT

CD-601-3

pen table= \\NDOT\RTW\W\Projects\NDOT\TSS\Projects\NDOT\TSS\Projects\TBA\Recovery\Details\_13x17.tbl  
 scale=63.073306:1.000000  
 date=28-SEP-2016 11:07  
 ID=TP2VLL  
 BDCBD-DT-ORIGINAL SHEET

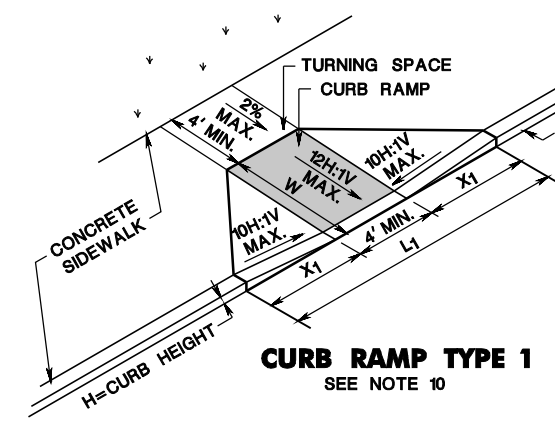

**CURB RAMP TYPE 1**  
SEE NOTE 10

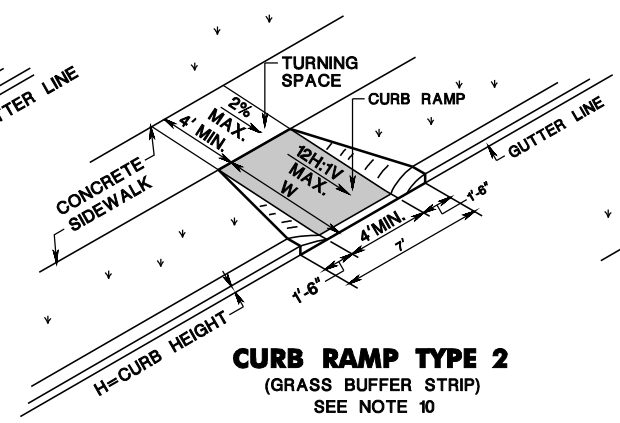

**CURB RAMP TYPE 2**  
(GRASS BUFFER STRIP)  
SEE NOTE 10

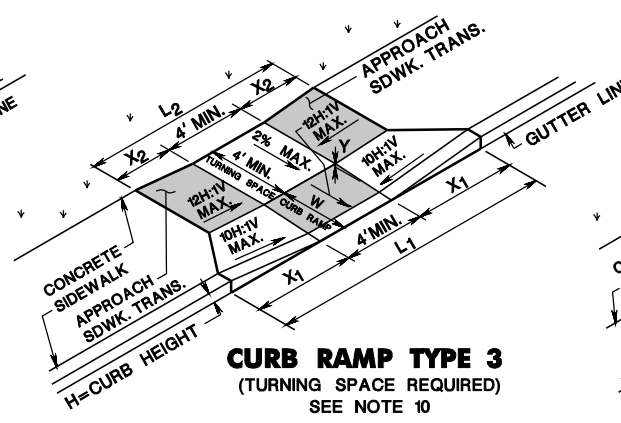

**CURB RAMP TYPE 3**  
(TURNING SPACE REQUIRED)  
SEE NOTE 10

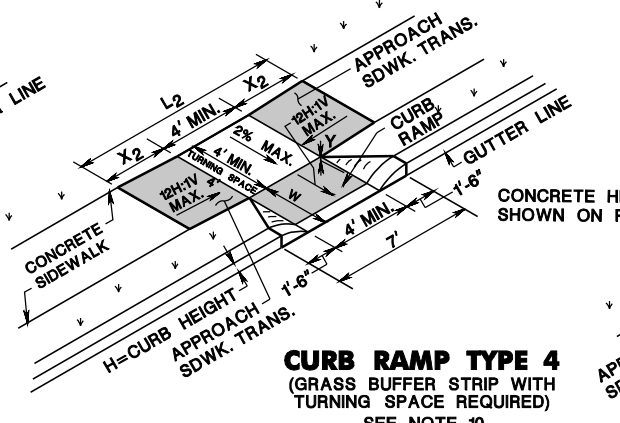

**CURB RAMP TYPE 4**  
(GRASS BUFFER STRIP WITH TURNING SPACE REQUIRED)  
SEE NOTE 10

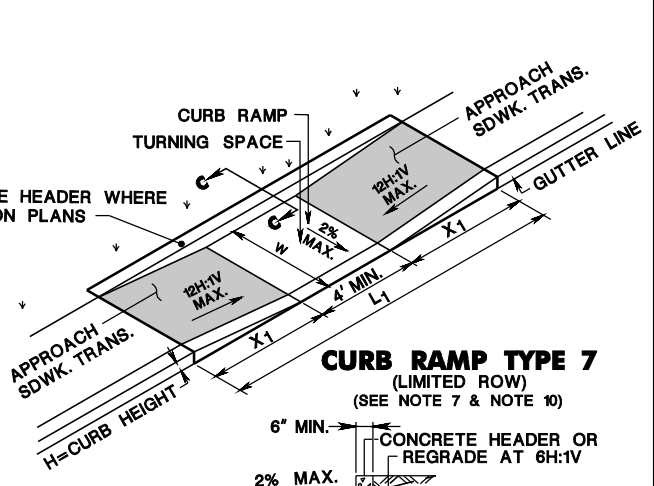

**CURB RAMP TYPE 7**  
(LIMITED ROW)  
(SEE NOTE 7 & NOTE 10)

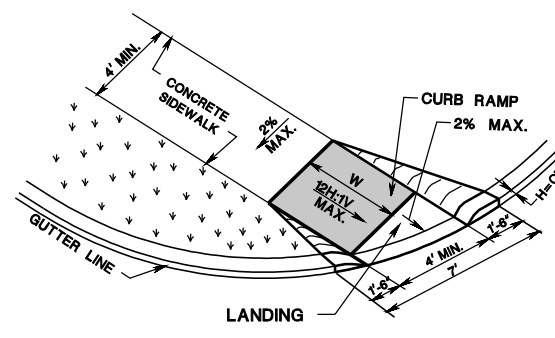
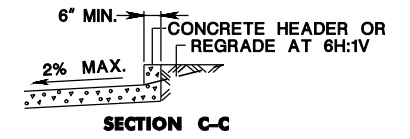

**CURB RAMP TYPE 5**

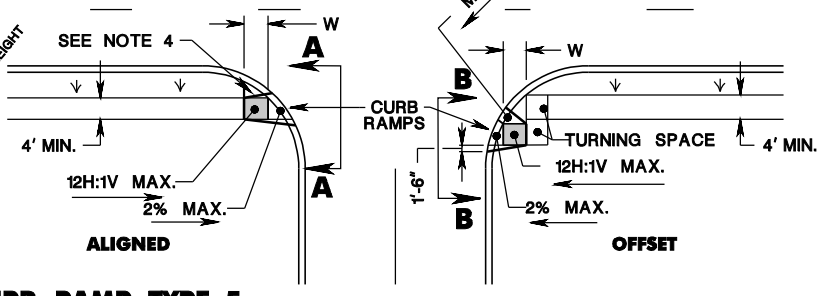

**CURB RAMP TYPE 6**

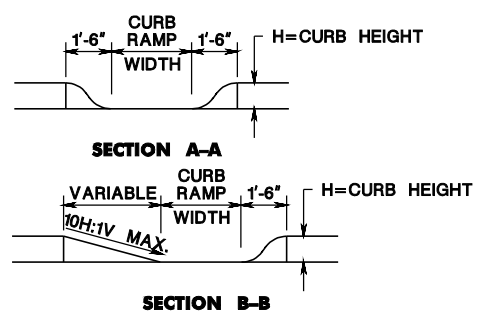

**NOTE:**  
CURB RAMP OPENING TO BE FLUSH WITH ROADWAY PAVEMENT (CURB RAMP TYPES 5 & 6).

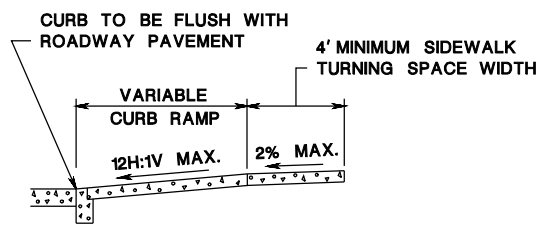

**SECTION THROUGH CURB RAMPS 1 THROUGH 4**

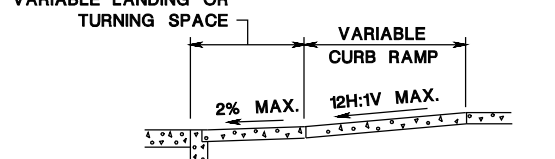

**SECTION THROUGH CURB RAMPS 5 AND 6**

**NOTES:**

- KEEP TURNING SPACE, APPROACH SIDEWALK TRANSITIONS, AND CURB RAMP CLEAR OF OBSTRUCTIONS THAT PROTRUDE ABOVE THE SURFACE.
- FOR DIMENSIONS SEE CD-606-3 AND CD-606-4
- CURB (DROPPED CURB) GUTTERLINE TO BE FLUSH WITH ROADWAY PAVEMENT THE ENTIRE WIDTH OF THE RAMP (4 FEET MIN.) AT ALL CURB RAMPS.
- FOR CURB RAMP TYPES 5 AND 6, IF A GRASS BUFFER DOES NOT EXIST, SLOPE CURB TO EQUAL SLOPE OF ADJACENT CURB RAMP.
- SIDEWALK AND CURB RAMP WITHIN AREA ENCLOSED BY HEAVY LINES INDICATES THE PAY LIMIT FOR CONCRETE SIDEWALK OF THE APPROPRIATE ADJACENT THICKNESS.
- CURB AND HEADER WITHIN AREA ENCLOSED BY HEAVY LINES INDICATES THE PAY LIMIT FOR VERTICAL CURB OR SLOPING CURB OF THE APPROPRIATE ADJACENT SIZE AND KIND.
- WHERE THE DISTANCE FROM THE GUTTER LINE TO THE OUTSIDE EDGE OF SIDEWALK IS 6 FEET OR LESS, USE CURB RAMP TYPE 7, INSTEAD OF CURB RAMP TYPE 1 THROUGH 4.
- CROSSWALKS AND STOP LINES MAY BE MARKED OR UNMARKED. SEE PLANS.
- THE 12H:1V MAX SLOPE IS THE RUNNING SLOPE FOR CURB RAMPS, BUT ONLY THE 12H:1V SLOPE MEASURED AS  $X_2$  IS THE RUNNING SLOPE FOR TYPE 3 AND TYPE 4 CURB RAMPS. ENSURE THE RUNNING SLOPE OF CURB RAMPS DOES NOT REQUIRE ITS LENGTH TO EXCEED 15 FEET. THE RUNNING SLOPE MAY EXCEED THE 12H:1V MAX SLOPE SO AS NOT TO EXCEED THE 15 FEET MAXIMUM LENGTH.
- CURB RAMP TYPE 1 THROUGH 7 ARE NORMALLY PLACED ON THE RADIUS RETURN AT THE INTERSECTION AND ON A TANGENT SECTION AS DRAWN.

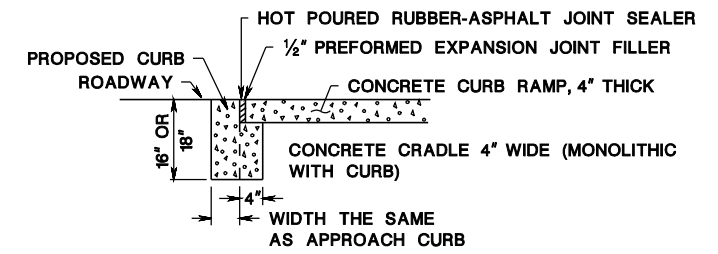

**DROPPED CURB AND CRADLE**

**CONCRETE SIDEWALK**  
(PUBLIC SIDEWALK CURB RAMP)  
N.T.S.

NEW JERSEY DEPARTMENT OF TRANSPORTATION

**CONSTRUCTION DETAILS**

**CURB RAMPS**

CD-606-1.1

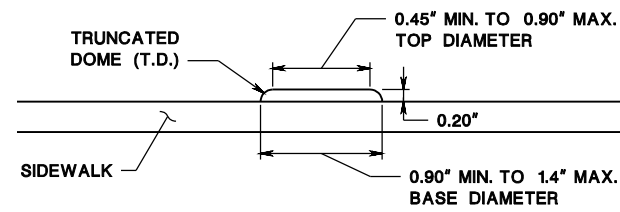
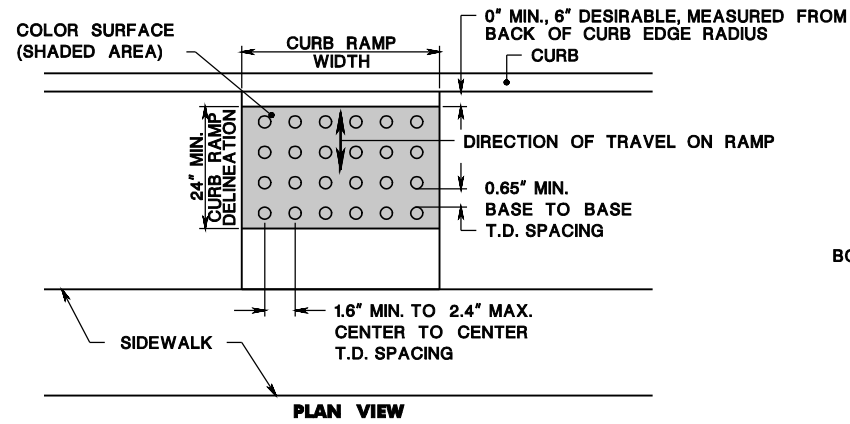

**DETECTABLE WARNING SURFACE**

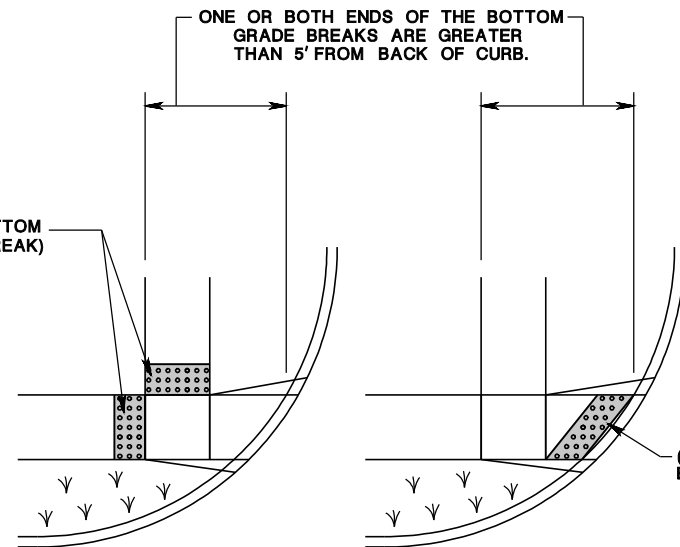
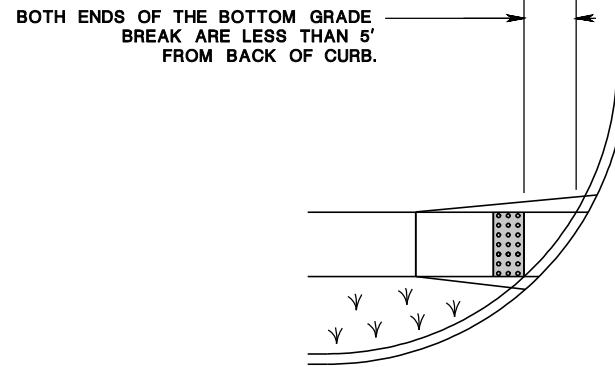

**PLACEMENT OF DETECTABLE WARNING SURFACE FOR CURB RAMP TYPE 5 AND 6**

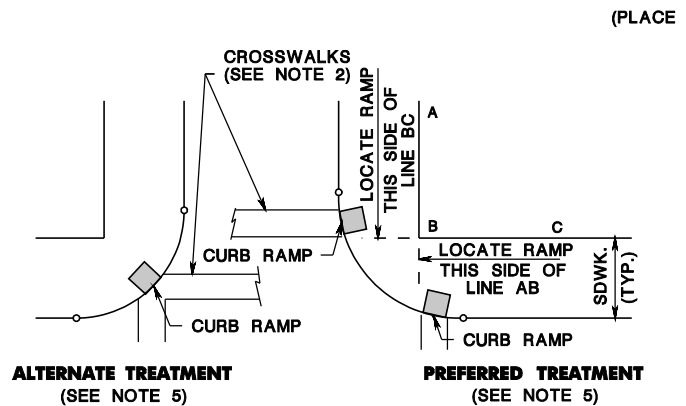

**LOCATION OF CURB RAMP TYPES 1, 2, 3, 4, & 7 FOR CROSSING PARALLEL AND PERPENDICULAR TO HIGHWAY**

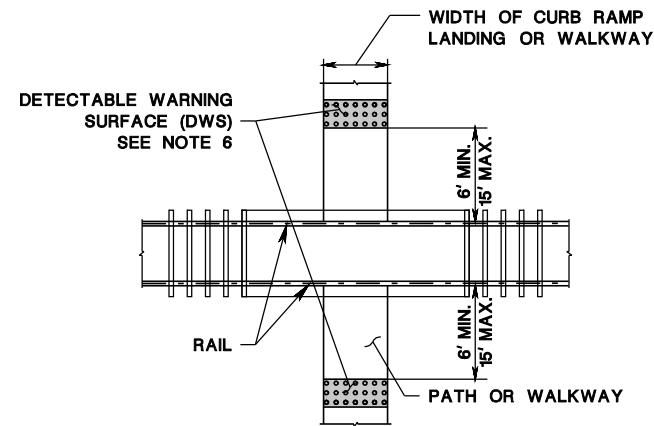

**PEDESTRIAN RAILROAD CROSSING**

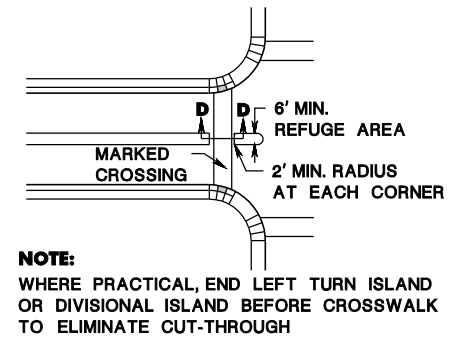

**NOTE:** WHERE PRACTICAL, END LEFT TURN ISLAND OR DIVISIONAL ISLAND BEFORE CROSSWALK TO ELIMINATE CUT-THROUGH

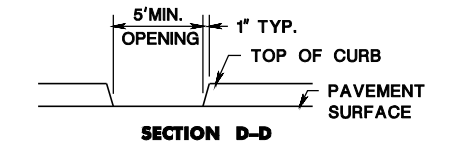

**NOTE:** 5' MIN. WIDE OPENING TO BE FLUSH WITH ROADWAY PAVEMENT

**PEDESTRIAN REFUGE ISLAND WALKWAY OPENING AT INTERSECTIONS**

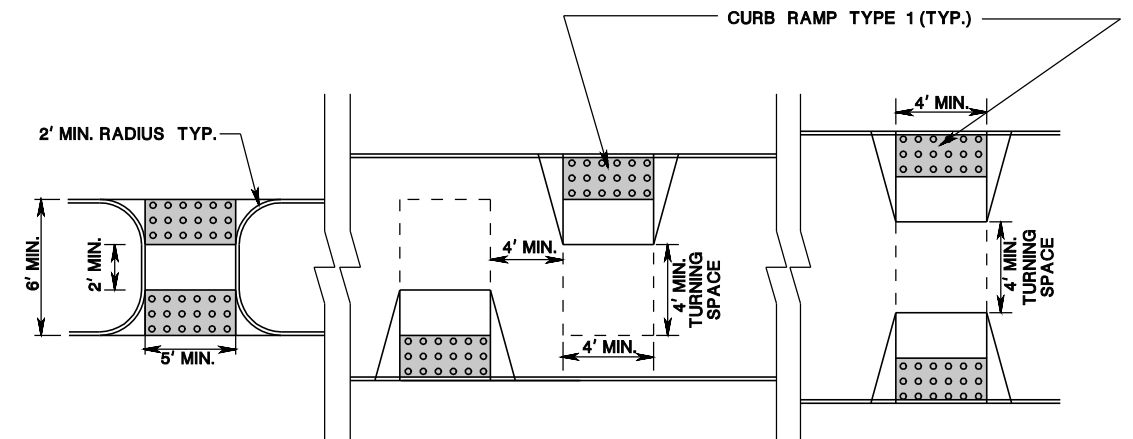

**NARROW ISLAND WIDTH (SEE NOTE 3)**

**MEDIUM ISLAND WIDTH (SEE NOTE 4)**

**LARGE ISLAND WIDTH (SEE NOTE 4)**

**PEDESTRIAN REFUGE ISLAND**

**DETECTABLE WARNING SURFACE N.T.S.**

**NOTES:**

- KEEP TURNING SPACE, APPROACH SIDEWALK TRANSITIONS, AND CURB RAMP CLEAR OF OBSTRUCTIONS THAT PROTRUDE ABOVE THE SURFACE.
- CROSSWALKS AND STOP LINES MAY BE MARKED OR UNMARKED, SEE PLANS.
- FOR NARROW ISLAND WIDTH, SEE PEDESTRIAN REFUGE ISLAND WALKWAY OPENING AT INTERSECTIONS DETAIL.
- FOR MEDIUM AND LARGE ISLAND WIDTH, SEE CURB RAMP TYPE 1 ON CD-606-1.
- CONSTRUCT CURB RAMP TYPES 1, 2, 3, 4, & 7 PERPENDICULAR TO CURBLINE, AS SHOWN.
- IF A CURB RAMP IS REQUIRED, THE LOCATION OF THE DETECTABLE WARNING SURFACE MUST BE AT THE BOTTOM OF THE RAMP AND WITHIN THE REQUIRED DISTANCE FROM THE RAIL.
- A STANDARD DETECTABLE WARNING (DWS) SURFACE IS NOT AVAILABLE TO FIT THIS APPLICATION, AND THEREFORE ONE WILL NEED TO BE CUSTOMIZED. THE DWS SHOULD COVER THE ENTIRE WIDTH OF THE RAMP. THE ROWS OF DOMES ON THE DWS SHOULD FOLLOW THE DIRECTION OF TRAVEL OF THE RAMP, SO PEDESTRIANS WHO USE MOBILE DEVICES CAN TRACK BETWEEN THE DOMES.

CD-606-2

NEW JERSEY DEPARTMENT OF TRANSPORTATION

**CONSTRUCTION DETAILS**

CD-606-2.1

**CURB RAMP TYPE 1**

Table with 5 columns: H INCHES, W FEET, X1U FEET, X1L FEET, L1 FEET. Rows for gutter line profile 0.0% with H values from 3 to 9.

Table with 5 columns: H INCHES, W FEET, X1U FEET, X1L FEET, L1 FEET. Rows for gutter line profile 1.0% with H values from 3 to 9.

Table with 5 columns: H INCHES, W FEET, X1U FEET, X1L FEET, L1 FEET. Rows for gutter line profile 2.0% with H values from 3 to 9.

Table with 5 columns: H INCHES, W FEET, X1U FEET, X1L FEET, L1 FEET. Rows for gutter line profile 3.0% with H values from 3 to 9.

Table with 5 columns: H INCHES, W FEET, X1U FEET, X1L FEET, L1 FEET. Rows for gutter line profile 4.0% with H values from 3 to 9.

Table with 5 columns: H INCHES, W FEET, X1U FEET, X1L FEET, L1 FEET. Rows for gutter line profile 5.0% with H values from 3 to 9.

Table with 5 columns: H INCHES, W FEET, X1U FEET, X1L FEET, L1 FEET. Rows for gutter line profile 6.0% with H values from 3 to 9.

Table with 5 columns: H INCHES, W FEET, X1U FEET, X1L FEET, L1 FEET. Rows for gutter line profile 7.0% with H values from 3 to 9.

**CURB RAMP TYPE 3**

Table with 10 columns: H INCHES, W FEET, X1U FEET, X1L FEET, L1 FEET, Y INCHES, X2U FEET, X2L FEET, L2 FEET. Rows for gutter line profile 0.0% with H values from 3 to 9.

Table with 10 columns: H INCHES, W FEET, X1U FEET, X1L FEET, L1 FEET, Y INCHES, X2U FEET, X2L FEET, L2 FEET. Rows for gutter line profile 3.0% with H values from 3 to 9.

Table with 10 columns: H INCHES, W FEET, X1U FEET, X1L FEET, L1 FEET, Y INCHES, X2U FEET, X2L FEET, L2 FEET. Rows for gutter line profile 3.5% with H values from 3 to 9.

Table with 10 columns: H INCHES, W FEET, X1U FEET, X1L FEET, L1 FEET, Y INCHES, X2U FEET, X2L FEET, L2 FEET. Rows for gutter line profile 4.0% with H values from 3 to 9.

Table with 10 columns: H INCHES, W FEET, X1U FEET, X1L FEET, L1 FEET, Y INCHES, X2U FEET, X2L FEET, L2 FEET. Rows for gutter line profile 3.0% with H values from 3 to 9.

Table with 10 columns: H INCHES, W FEET, X1U FEET, X1L FEET, L1 FEET, Y INCHES, X2U FEET, X2L FEET, L2 FEET. Rows for gutter line profile 3.5% with H values from 3 to 9.

Table with 10 columns: H INCHES, W FEET, X1U FEET, X1L FEET, L1 FEET, Y INCHES, X2U FEET, X2L FEET, L2 FEET. Rows for gutter line profile 4.0% with H values from 3 to 9.

Table with 5 columns: H INCHES, W FEET, X1U FEET, X1L FEET, L1 FEET. Rows for gutter line profile 0-8% with H values from 3 to 9.

Table with 10 columns: H INCHES, W FEET, X1U FEET, X1L FEET, L1 FEET, Y INCHES, X2U FEET, X2L FEET, L2 FEET. Rows for gutter line profile 1.0% with H values from 3 to 9.

Table with 10 columns: H INCHES, W FEET, X1U FEET, X1L FEET, L1 FEET, Y INCHES, X2U FEET, X2L FEET, L2 FEET. Rows for gutter line profile 3.0% with H values from 3 to 9.

Table with 10 columns: H INCHES, W FEET, X1U FEET, X1L FEET, L1 FEET, Y INCHES, X2U FEET, X2L FEET, L2 FEET. Rows for gutter line profile 3.5% with H values from 3 to 9.

Table with 10 columns: H INCHES, W FEET, X1U FEET, X1L FEET, L1 FEET, Y INCHES, X2U FEET, X2L FEET, L2 FEET. Rows for gutter line profile 4.0% with H values from 3 to 9.

Table with 10 columns: H INCHES, W FEET, X1U FEET, X1L FEET, L1 FEET, Y INCHES, X2U FEET, X2L FEET, L2 FEET. Rows for gutter line profile 5.0% with H values from 3 to 9.

Table with 10 columns: H INCHES, W FEET, X1U FEET, X1L FEET, L1 FEET, Y INCHES, X2U FEET, X2L FEET, L2 FEET. Rows for gutter line profile 5.0% with H values from 3 to 9.

Table with 10 columns: H INCHES, W FEET, X1U FEET, X1L FEET, L1 FEET, Y INCHES, X2U FEET, X2L FEET, L2 FEET. Rows for gutter line profile 2.0% with H values from 3 to 9.

Table with 10 columns: H INCHES, W FEET, X1U FEET, X1L FEET, L1 FEET, Y INCHES, X2U FEET, X2L FEET, L2 FEET. Rows for gutter line profile 3.0% with H values from 3 to 9.

Table with 10 columns: H INCHES, W FEET, X1U FEET, X1L FEET, L1 FEET, Y INCHES, X2U FEET, X2L FEET, L2 FEET. Rows for gutter line profile 3.5% with H values from 3 to 9.

Table with 10 columns: H INCHES, W FEET, X1U FEET, X1L FEET, L1 FEET, Y INCHES, X2U FEET, X2L FEET, L2 FEET. Rows for gutter line profile 4.0% with H values from 3 to 9.

Table with 10 columns: H INCHES, W FEET, X1U FEET, X1L FEET, L1 FEET, Y INCHES, X2U FEET, X2L FEET, L2 FEET. Rows for gutter line profile 6.0% with H values from 3 to 9.

Table with 10 columns: H INCHES, W FEET, X1U FEET, X1L FEET, L1 FEET, Y INCHES, X2U FEET, X2L FEET, L2 FEET. Rows for gutter line profile 6.0% with H values from 3 to 9.

Table with 10 columns: H INCHES, W FEET, X1U FEET, X1L FEET, L1 FEET, Y INCHES, X2U FEET, X2L FEET, L2 FEET. Rows for gutter line profile 3.0% with H values from 3 to 9.

Table with 10 columns: H INCHES, W FEET, X1U FEET, X1L FEET, L1 FEET, Y INCHES, X2U FEET, X2L FEET, L2 FEET. Rows for gutter line profile 3.0% with H values from 3 to 9.

Table with 10 columns: H INCHES, W FEET, X1U FEET, X1L FEET, L1 FEET, Y INCHES, X2U FEET, X2L FEET, L2 FEET. Rows for gutter line profile 3.5% with H values from 3 to 9.

Table with 10 columns: H INCHES, W FEET, X1U FEET, X1L FEET, L1 FEET, Y INCHES, X2U FEET, X2L FEET, L2 FEET. Rows for gutter line profile 4.0% with H values from 3 to 9.

Table with 10 columns: H INCHES, W FEET, X1U FEET, X1L FEET, L1 FEET, Y INCHES, X2U FEET, X2L FEET, L2 FEET. Rows for gutter line profile 7.0% with H values from 3 to 9.

Table with 10 columns: H INCHES, W FEET, X1U FEET, X1L FEET, L1 FEET, Y INCHES, X2U FEET, X2L FEET, L2 FEET. Rows for gutter line profile 7.0% with H values from 3 to 9.

**NOTES:**

- 1. FOR CURB RAMP TYPES, SEE CD-606-1.
2. THE ABOVE TABLES ARE BASED ON THE SPECIFIC GUTTER PROFILE REFERENCED. THEY DO NOT TAKE INTO ACCOUNT VARIATIONS IN THE GUTTER PROFILE. THE ABOVE TABLES TO BE USED BY THE DESIGNERS AND CONTRACTORS TO GET APPROXIMATE DIMENSIONS OF THE CURB RAMP AT EACH LOCATION. FINAL DIMENSIONS WILL BE DETERMINED BY ACTUAL MEASUREMENTS IN THE FIELD DURING CONSTRUCTION.
3. THE 12H:1V MAX SLOPE IS THE RUNNING SLOPE FOR CURB RAMPS, BUT ONLY THE 12H:1V SLOPE MEASURED AS X IS THE RUNNING SLOPE FOR TYPE 3 AND TYPE 4 CURB RAMPS. ENSURE THE RUNNING SLOPE OF CURB RAMPS DOES NOT REQUIRE ITS LENGTH TO EXCEED 15 FEET. THE RUNNING SLOPE MAY EXCEED THE 12H:1V MAX SLOPE SO AS NOT TO EXCEED THE 15 FEET MAXIMUM LENGTH. THE TABLES ALREADY APPLY THE 15 FEET RULE FOR THOSE CALCULATED LENGTHS WHICH EXCEED 15 FEET.
4. DIMENSIONS SHOWN IN TABLES ARE FOR 3 INCH TO 9 INCH CURB HEIGHTS. WHERE THE CURB HEIGHTS ARE OTHER THAN WHAT IS PROVIDED IN THE TABLES, THE DIMENSIONS OF THE RAMPS WILL HAVE TO BE CALCULATED BASED ON CROSS SLOPES SHOWN.

**LEGEND**

- U = UPPER SIDE OF GUTTER LINE PROFILE
L = LOWER SIDE OF GUTTER LINE PROFILE
FOR THE OTHER ABBREVIATIONS - REFER TO CD-606-1
\* TYPE 3 RAMP IS NOT APPLICABLE, USE TYPE 1
\*\* TYPE 4 RAMP IS NOT APPLICABLE, USE TYPE 2

**CONCRETE SIDEWALK**  
(PUBLIC SIDEWALK CURB RAMP TABLES)  
N.T.S.

CD-606-3

NEW JERSEY DEPARTMENT OF TRANSPORTATION

**CONSTRUCTION DETAILS**

CD-606-3.1







**COUNTY OF HUDSON**  
**DEPARTMENT OF ROADS AND PUBLIC PROPERTY**  
**OFFICE OF THE COUNTY ENGINEER**  
BERGEN SQUARE CENTER  
830 BERGEN AVENUE, FLOOR. #6B  
JERSEY CITY, NEW JERSEY 07306  
TELEPHONE: (201) 369-4340  
FAX: (201) 369-4346

**THOMAS MALAVASI, PE, PP, CME, CPWM**  
COUNTY ENGINEER

**JOSEPH F. GLEMBOCKI, PE**  
ASSISTANT COUNTY ENGINEER

**ROBERT A YANNAZZO, AIA**  
CHIEF ARCHITECT

**THOMAS A. DeGISE**  
COUNTY EXECUTIVE

**DENISE C. D'ALESSANDRO**  
DIRECTOR

**DUMPSTER PERMIT**



**Dumpster Fee: \$25.00 per month**

**Date:** \_\_\_\_\_

**This permit provides permission for a dumpster to be placed at the following address:**

\_\_\_\_\_  
\_\_\_\_\_

**Dumpster will be on site** \_\_\_\_\_  
**From** \_\_\_\_\_ **Until** \_\_\_\_\_

**Total Fee (\$25 x number of months) = \$** \_\_\_\_\_

**In accordance with a County Resolution adopted on March 26, 1975 by the Board of Chosen Freeholders, ALL DUMPSTERS on a Roadway or Property owned and Controlled by the County of Hudson must meet the following conditions:**

- 1. All Dumpsters must be striped diagonally with yellow reflective paint.**
- 2. A flashing light similar to that used on highway construction shall be mounted on both ends of the dumpster so that it's clearly visible to motorists.**

**Name of Dumpster Company:** \_\_\_\_\_

**Company Address:** \_\_\_\_\_  
\_\_\_\_\_

**Application** \_\_\_\_\_ **Title :** \_\_\_\_\_ **Date:** \_\_\_\_\_  
**Approved By:** \_\_\_\_\_

BOARD OF COMMISSIONERS  
COUNTY OF HUDSON

ORDINANCE

No. 533-8-2023

On Motion of Commissioner Board as a Whole  
Seconded by Commissioner \_\_\_\_\_

AN ORDINANCE ESTABLISHING  
THE RULES AND REGULATIONS  
GOVERNING DEMOLITION AND CONSTRUCTION PERMITS ABUTTING  
COUNTY OWNED PROPERTY AND RIGHTS OF WAY

WHEREAS, upon review by the County of Hudson (the "County"), it has been discovered that a need exists to ensure public property and public rights of way are protected in the event of accidents or damage during demolition and construction projects in the County and it is in the best interest of the County public safety, health, and general welfare to ensure that this need is addressed; and

WHEREAS, pursuant to the provisions of N.J.S.A. 40:41A-38, 40:41A-101 and 27:16-31 the County has the authority to establish rules and regulations for the protection of these interests; and

WHEREAS, the following requirements and the imposition of penalties for any work performed contrary to these requirements are clearly established and to be followed.

NOW, THEREFORE, BE IT ORDAINED by the Board of Commissioners of the County that:

1. The above recitals are incorporated herein as though fully set forth at length.
2. All entities, both public and private, that apply for construction or demolition permits for projects abutting County property or a County right of way must submit to the County, in addition to any approval from the reviewing entity, a valid certificate of insurance providing coverage at the same limits as required by the reviewing entity and said certificate shall name the County as an additional insured. The entity performing work must also certify that it will hold the County harmless for all demolition and construction-related incidents resulting in damages.
3. No work shall commence until a valid certificate of insurance is delivered to the County for review and approved by the County Engineer. Certificates shall be sent to the County Engineer at the Hudson County Division of Engineering, 830 Bergen Avenue, Suite 6B, Jersey City, NJ 07306 prior to the performing of work. Upon receipt by the County Engineer of the COI and necessary indemnification forms, the County shall notify the municipality and interested parties of adequate processing within three (3) business days, or the review will be deemed satisfactory.
4. Any violations of the above procedure shall be subject to a penalty of \$1,000.00 per each day of noncompliance, plus damages incurred by the County. Any entity wishing to appeal a violation issued pursuant to this regulation shall appeal to a Court of jurisdiction per N.J.S.A. 40:24-9.

**BOARD OF COMMISSIONERS  
COUNTY OF HUDSON**

**ORDINANCE**

No.

On Motion of Commissioner \_\_\_\_\_  
Seconded by Commissioner \_\_\_\_\_

5. This Ordinance shall take effect in the manner prescribed by law.

Commissioner	Aye	Nay	Abst.	N.P.	Commissioner	Aye	Nay	Abst.	N.P.
Walker	✓				Cedeflo	✓			
Cifelli	✓				Rodriguez	✓			
Kopacz	✓				Baselice	✓			
Aponte-Lipski				✓	Chairperson Romano	✓			
O'Dea	✓								

It is hereby certified that at a regular meeting of the Board of County Commissioners of the County of Hudson held on the 10 day of Aug A.D. 2023, the foregoing ordinance was finally adopted with 8 members voting in the affirmative and 0 in the negative.

  
 \_\_\_\_\_ Clerk

The foregoing ordinance having been duly presented to me, I hereby \_\_\_\_\_ the same

Dated: A.D. 2023

\_\_\_\_\_  
County Executive

BOARD OF COMMISSIONERS  
COUNTY OF HUDSON

ORDINANCE

No. 534-8-2023

On Motion of Commissioner Board as a Whole  
Seconded by Commissioner \_\_\_\_\_

AN ORDINANCE AMENDING ORDINANCE NUMBER 116-2-1999  
REGARDING THE RULES AND REGULATIONS  
GOVERNING ROAD OPENING PERMITS

WHEREAS, Ordinance Number 116-2-1999 established the rules and regulations governing road opening permits; and

WHEREAS, it has been discovered that a need exists for the imposition of penalties for any work performed on a County roadway without a permit, for any work performed contrary to or outside of the scope of that work approved by an issued road opening permit and for work performed which in any way violates the provisions of the rules and regulations governing road opening permits; and

WHEREAS, it is in the best interest of the County to ensure that these penalty provisions are clearly established and followed.

NOW, THEREFORE, BE IT ORDAINED by the Board of Commissioners of the County of Hudson that:

1. The above recitals are incorporated herein as though fully set forth at length.
2. Ordinance Number 116-2-1999 is, by this Act, amended to reflect the following:

Sections I through IX – No Change.

Section X – add the following language.

No road closures shall take place without a traffic control plan approved by the County of Hudson and the affected Municipality.

Sections XI through XIV – No Change.

Section XV – Penalties.

(existing section deleted and add the following language)

- A. Any person, firm, corporation, contractor or public utility who shall violate any of the provisions of this Ordinance, who shall violate or fail to comply with any order or regulation made under the provisions of this section, who shall perform any work without a permit, perform any work contrary to or outside of the scope of work approved by an issued permit or perform work which in any way violates the provisions of the rules and regulations governing road opening permits, shall severally for each and every such

violation or noncompliance, respectively, when not otherwise provided for within this Ordinance and Ordinance No. 405-6-2017, be subject to the following penalties:

\$1,000.00 per day for the first violation;

\$1,500.00 per day for the second violation;

\$2,000.00 per day for the third violation;

as well as reimbursement of any and all costs incurred by the County to address the violation.

- B. Should any person, firm, corporation, contractor or public utility, in violating any of the provisions of this section, after notice of such violation, continue such violation, each twenty-four (24) hours that the same shall be continued shall be construed to constitute a separate and distinct violation.
- C. Any monies due to the County in payment of a penalty for violation of this Ordinance and/or reimbursements due to the County shall be billed to the permittee by the County Engineer and shall be paid by the permittee within thirty (30) days after receipt. Failure of a permittee to pay such penalties shall result in the permittee paying the maximum interest rate allowed by law, as well as any attorney's fees and costs incurred by the County in furtherance of the collection of said monies.
- D. The County Engineer shall have the authority to deny all future permits until all monies due to the County are paid in full.

3. This Ordinance shall take effect in the manner prescribed by law.

Commissioner	Aye	Nay	Abst.	N.P.	Commissioner	Aye	Nay	Abst.	N.P.
Walker	✓				Cedeño	✓			
Cifelli	✓				Rodriguez	✓			
Kopacz	✓				Bnselice	✓			
Aponte-Lipski				✓	Chairperson Romano	✓			
O'Dea	✓								

It is hereby certified that at a regular meeting of the Board of County Commissioners of the County of Hudson held on the 10 day of Aug A.D. 2023, the foregoing ordinance was finally adopted with 8 members voting in the affirmative and 0 in the negative.

 Clerk

The foregoing ordinance having been duly presented to me, I hereby \_\_\_\_\_ the same

Dated:

A.D. 2023

\_\_\_\_\_  
County Executive